

Design of the scour protection as part of the DELTA 21 project

Author: Zhaoyi Li

Student number: 4831713

Supervisor: Mark Voorendt, Alessandro Antonini

Company supervisor: Huub Lavooij

Date: 25/09/2019



Preface

This study was performed within the framework of technical design of the DELTA 21 project. This report deals with the design of scour protection for different components of the DELTA 21 project. This study is an additional thesis as part of my master program in Civil Engineering at Delft University of Technology.

I would like to thank the members of my supervisors Mr. Voorendt and Mr. Antonini for their efforts and critical advice. Furthermore I would like to thank Mr. Lavooij for his help during my research and offering such a opportunity to take part in the DELTA 21 project.

Zhaoyi Li

September 2019

Supervisor:

Mark Voorendt TU Delft

Alessandro Antonini TU Delft

Huub Lavooij Delta21

CONTENTS

1 INTRODUCTION	5
1.1 Methodology	5
1.2 Problem analysis	6
1.3 Functional parameters of the Delta 21 concept	8
1.4 Objective	10
1.5 Required failure probability	11
2 BOUNDARY CONDITION	15
2.1 Hydraulic conditions	15
2.2 Geological setting	23
3 SCOUR PROTECTION DESIGN	25
3.1 Flow pattern calculation	25
3.2 Armour layer design	32
3.3 Probabilistic check	40
3.4 Filter layer design	42
4 EXECUTION PLAN	45
4.1 Required material	45
4.2 Construction stages	45
4.3 Risk analysis	46
5 CONCLUSION AND RECOMMENDATION	46
5.1 Conclusion	46
5.2 Recommendation	47
REDERENCE	48

APPENDIX A EXTREME VALUE ANALYSIS OF WAVE CONDITION	49
APPENDIX B BOTTOM PROFILE	52
APPENDIX C RESULT OF PROB2B	53
APPENDIX D SKETCH OF CROSS-SECTION	54

1 Introduction

For hydraulic infrastructure, erosion problem has always been non-negligible. Scour development can threaten the stability of structures and lead to destructive damage. In some condition, the cause of erosion is the disturbance of the flow by the structure, where removing the cause is not an option to solve the problem (Schierec, 2016). Then, an increase of the stability of the bed by means of a bottom protection design is required.

As part of the DELTA 21 project, a scour protection must be designed to prevent a potential upcoming erosion problem. The flow velocity at different locations under different working conditions has to be analysed to derive a sufficient design.

1.1 Methodology

In this section, steps of the engineering design process is introduced as framework of this study. Furthermore, as basic of the design, method for data collection and analysis is presented.

Design process

The engineering design process is a series of steps that engineers follow to come up with a solution to a problem. Start with problem definition, and follows with background research and requirements determination. Then for problem with various solutions, the optimal solution need to be decided. With the chosen solution, we can get the preliminary design. This result needs to be tested if it meet requirement or need further adjustment. Then, one can get the final result.

Data collection

In order to get an optimal solution for the defined problem, data needs to be gathered from scientific sources. Data for this study has mainly two sources, literature research and background of DELTA 21 project. The Rijkswaterstaat website, DINOLoket or the Pro-Tide website, Waveclimate website, Windfinder website and Navionics website provide accurate data set and relevant research papers that are needed.

Data analysis

The data collected is processed in different software to get proper measurements for the design. Basic calculation is done in Excel and Maple. SwanOne is used onshore wave condition simulation. Furthermore Prob2B is used for probabilistic approach calculation.

1.2 Problem analysis

With the looming threat of sea level rise and increasing needs for clean, renewable energy due to climate change, some human interventions need to be taken place to guarantee the flood safety and energy demand. This triggered the generation of Delta 21 project. DELTA 21 is a unique spatial plan with three ambitions: flood safety, energy storage and nature restoration. It is located west of the Haringvliet and adjacent to the Maasvlakte 2, shown in Figure 1.

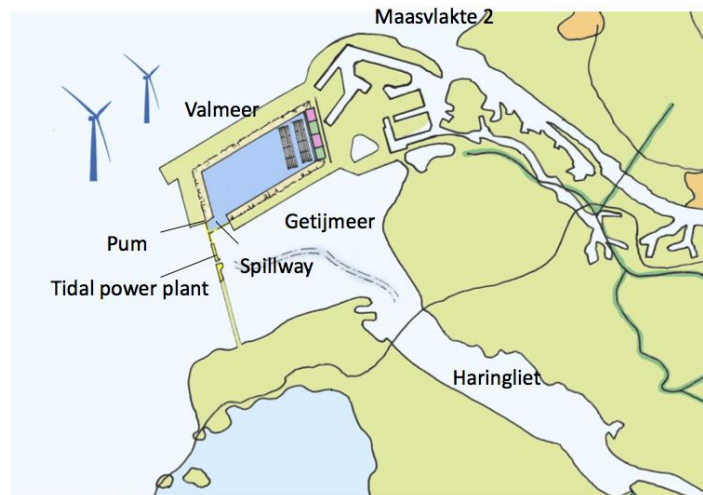

Figure 1: Layout of DELTA 21 project (Berke and Lavooij, 2018)

The Delta 21 project comprises a tidal lake (Getijmeer) and a storage basin (Valmeer) with a size of 20 km². There are basically two working conditions for DELTA 21 project depends on the appearance of storm on the sea side and extreme discharge from the river.

When there is no storm and the river discharge is within standard, the tidal power plant is turned on, the sea water is exchanged twice a day in Getijmeer through the tidal power plant and energy is generated through turbines. The river discharge can be released through the tidal power plant, as long as the discharge doesn't reach an extreme value. In the very deep Valmeer, there will also be an exchange of the sea water through the pump. This daily operation of the pump system is just meant to keep the DELTA 21 project ready for flash flood.

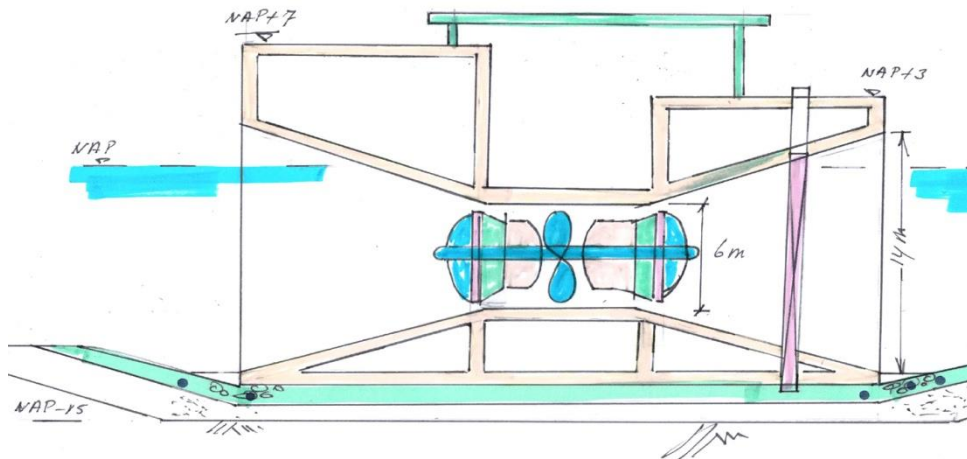

Figure 2: Cross section of Turbines at tidal power plant (Berke and Lavooij, 2018)

If there is storm on the seaside or extreme water discharge from the river, the tidal power plant will be shut down, river discharge will flow into Valmeer through spillway and be pumped out into the sea through the pumping system. In this way, the DELTA 21 plan can offer protection not only for the area inside the Haringvliet dike, but also to the area around Dordrecht.

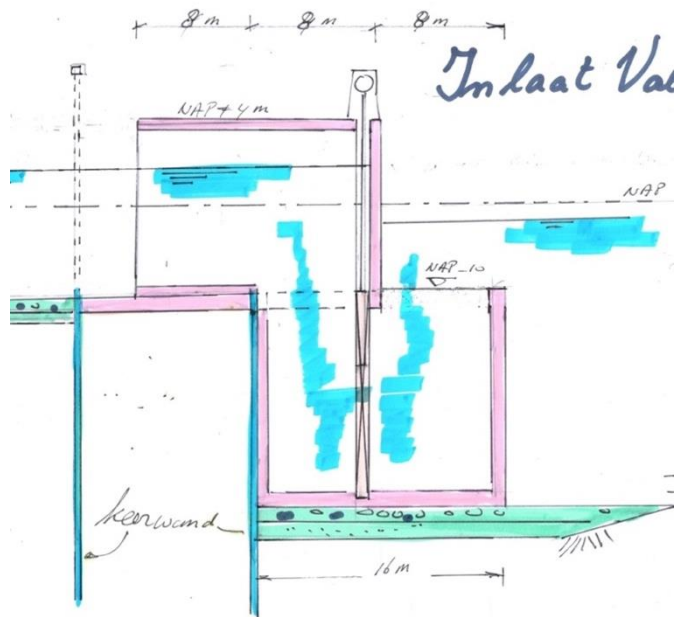

Figure 3: Cross section of spillway (Berke and Lavooij, 2018)

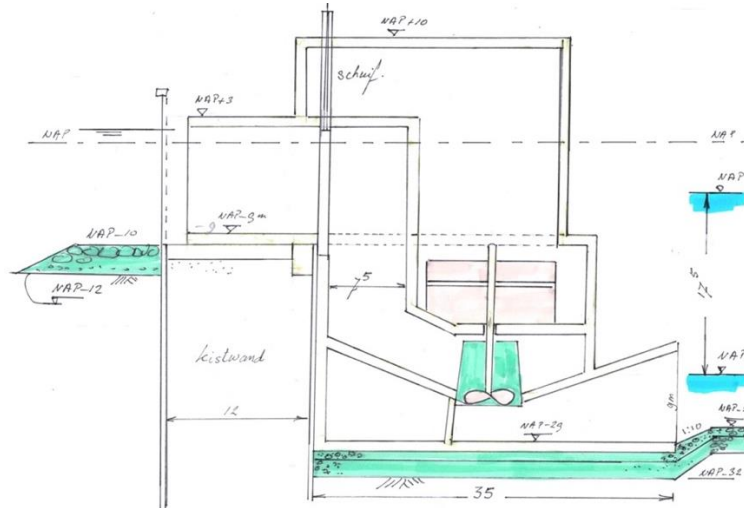

Figure 4: Cross section of pump at Valmeer (Berke and Lavooij, 2018)

To prevent destructive erosion and guarantee functioning of the project, scour protection is needed at specific locations. For the daily working scenario, scour protection should be placed at both sides of in-outlet of the Getijmeer. During a flood scenario, the flow velocity near the pump and spillway of the Valmeer is extremely large and may cause erosion, so special attention will be paid on scour protection over that part.

1.3 Functional parameters of the Delta 21 concept

Tidal power plant

For the Getijmeer, a direct exit to the sea is needed for the discharge of the river water, which must be discharged from the Haringvliet to the North Sea. To allow the maximum tide in the Haringvliet, the Haringvliet locks are permanently open and tidal turbines have been installed in the dam of the Getijmeer. With the western part of the Haringvliet, Lake Getijmeer has a total surface area of more than 120 km². For the housing of the tide turbines in the Getijmeer, caissons have been chosen, which are manufactured in 2 length parts of 200 m each (Berke and Lavooij, 2018).

The dam contains 40 turbines of 1.5 MW each, a total of 60 MW and the turbines have a diameter of 6 m and the turbine remain submerged during working. For each turbine a gross width of 10 m has been calculated. The total length of the construction for the 40 turbines of 1.5 MW is approximately 400 m. During working condition where there are no storm and extreme water discharge, the tidal power plant can release maximumly 4,000 m³/s of discharge from the river.

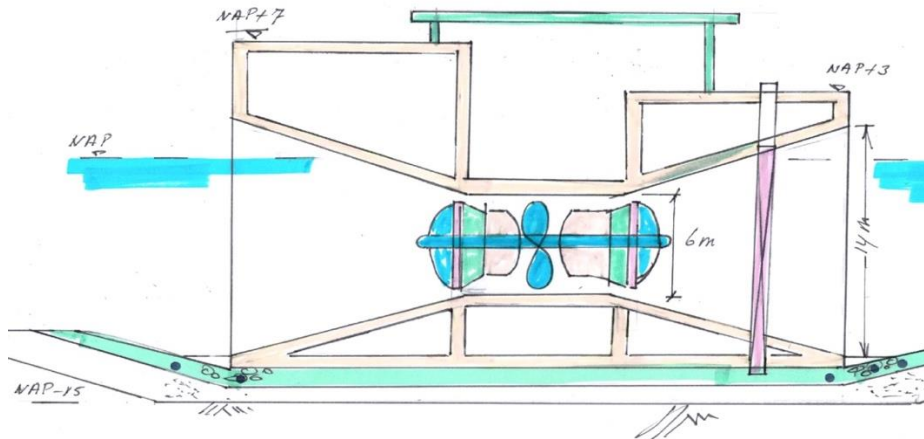

Figure 5: Cross section of Turbines at tidal power plant (Berke and Lavooij, 2018)

Pumping station of Valmeer

The Valmeer is attached to the north side against Maasvlakte 2. To be able to empty the Valmeer in 12 hours, 93 pumps/turbines of 20 MW each are required, require a total capacity of 1401MW. The 93 pumps / turbines are housed in concrete constructions caissons with a total length of approximately 500 m. For each of the single outlet orifice, the width is estimated to be 5 m. The pumps must be able to drain up to 10,000 m³/s of water and be able to work as a turbine to temporarily generate energy in a Valmeer (Berke and Lavooij, 2018).

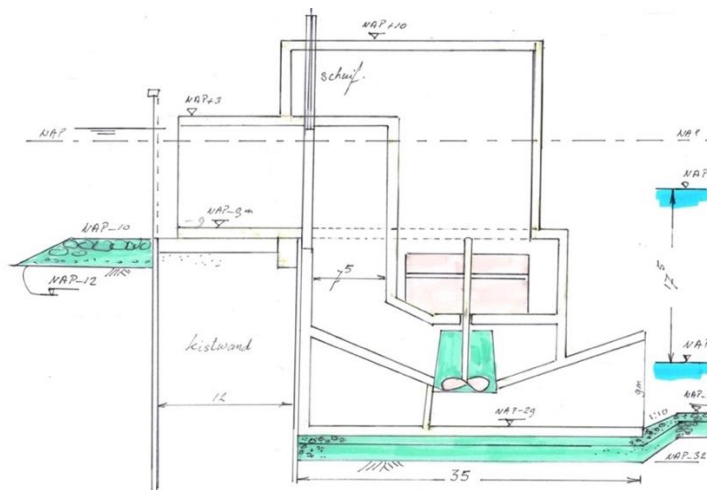

Figure 6: Cross section of pump at Valmeer (Berke and Lavooij, 2018)

Spillway

The design and construction of the overflow takes place in the same way as the housing for the pumps / turbines. For this, two caissons of 180 m each are planned and also two that are placed on top. The width of the spillway thus becomes approximately 360 m. Without design details, the width of single outlet is set to be

5m. The maximum discharge through the spillway will be constant with the capacity of pumping station, which is $10,000 \text{ m}^3/\text{s}$. Because the water level in the Getijmeer is lower and there are no waves, the top of the structure can, however, be limited to NAP + 5 m. third part. The caissons are also manufactured in the construction (Berke and Lavooij, 2018).

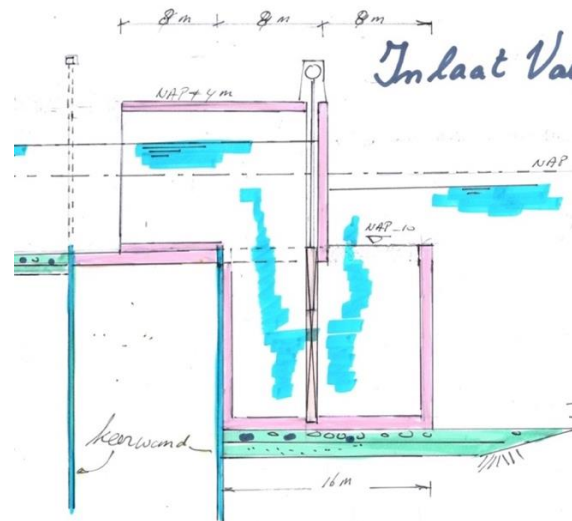

Figure 7: Cross section of spillway (Berke and Lavooij, 2018)

1.4 Objective

The main objective for this report is to obtain a feasible design of the scour protection for the DELTA 21 project. Due to the complex regulatory mechanism of the water level in the Valmeer and limited time for this project, the scour protection of the pump and spillway at the Valmeer side will not be considered in the design. So the project objective composed of three part, shown in Figure 8:

- (1) design of scour protection of the tidal power plant at both the Getijmeer side and sea side;
- (2) design of scour protection of the pumping station at sea side;
- (3) design of scour protection at the Getijmeer side near the spillway.

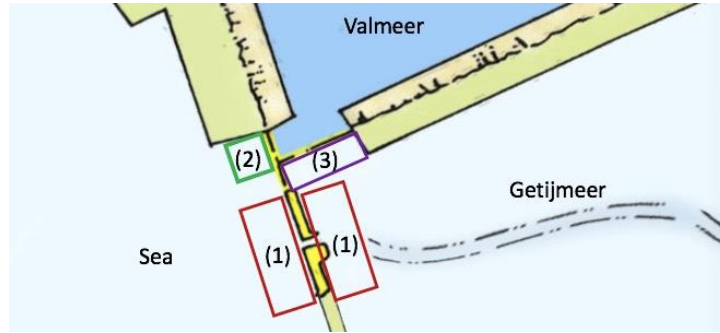

Figure 8: Location of different parts of scour protection for Delta 21.

The proposed design should satisfy the stability requirement during the design lifetime of the DELTA 21 project and should be simple and practical when it comes to the construction and maintenance phase. For the final scour protection, it consists mainly of two part, armour layer and filter layer. In the design, typical type of elements for the armour layer and type of filter will be decided at different locations and further dimensioned based on stability requirement.

1.5 Required failure probability

Design of the scour protection needs to satisfy certain stability requirement. For each part of the design, a specified probability of failure during the design and a target return period need to be decided. The DELTA 21 project is constructed for a functional lifetime of 100 years. Transformation of overall failure probability and return period follows from the Poisson distribution (Van den Bos and Verhagen, 2018).

$$R = \frac{T_L}{-\ln(1 - P_{f,TL})}$$

Where:

$P_{f,TL}$ =probability of failure within the lifetime of the structure

T_L =design lifetime of the structure

R = the return period

For the design of scour protection at the tidal power plant, which is related to the daily working condition with no storm and extreme river discharge, the stability requirement is based on the serviceability limit state (SLS), which corresponds to limitation of use and acceptable damage that can be repaired. A relatively high failure probability can be accepted, since only economic losses is expected. For scour protection, SLS condition is related to movements of few particles in the top layer and material in the base layer is not transported. Repair can be accepted to happen once a year. The target return period is assumed to be 1.

Ultimate Limit State (ULS) will be considered when it comes to the design of scour protection at pumping station and spill way under extreme storm or river discharge. This is because, consequence for the failure of scour protections related to flood defense can be large number fatalities, so require higher safety standard. ULS concerns the survival of the structure under extreme conditions. Here it is related to the failure of all layers of the scour protection and sediment transport over the entire bed.



Figure 9: New safety standard for flood defense (Jonkman and Jorissen , 2018)

According to the new standards for flood protection in Netherlands, the statutory flood protection standards for Rockanje at the estuary is 1/10,000 annually (Jonkman and Jorissen , 2018), shown in Figure 9. But the flood protection may fail due to different failure modes and also for the bed protection design only a section of the flood protection is considered.

Consider the new flood protection formed by the DELTA 21 project is composed of the tidal barrier and the seaside edge of the Valmeer, as shown in Figure 10 with red line. Then the pumping station is part of the flood protection and needs to satisfy the stability requirement for flood protection. While, the spillway is within the flood protection and its failure can't results in series economic damage and fatalities. Therefore lower safety standard can be applied for the scour protection.



Figure 10: The new flood protection by the DELTA 21 project

While for design of bed protection at the pumping station, only one failure modes at the given section of the flood protection is considered, so the safety standards for the design needs to be further analysed based on given standard. For the new safety standards the first two steps are incorporated in the following formulae which shows how a failure probability for a section i of a flood defense for a specific failure mechanism j can be derived (Jonkman and Jorissen , 2018).

$$P_{req,i,j} = \frac{\omega_j}{N_j} * P_{req}$$

$$N_j = 1 + \frac{a_j * L}{b_j}$$

where:

$P_{req,i,j}$ =required annual failure probability for section i and failure mechanism j [-]

ω_j =maximum contribution of failure mechanism j to the system failure probability [-]

N_j =length effect factor [-]

P_{req} = required annual failure probability for the dike trajectory [-]

a_j =fraction of the trajectory's length that is sensitive to failure mechanism j [-]

L =length of the trajectory [m]

b_j =length of a typical independent section for failure mechanism j [m]

Here in this case, due to failure of the scour protection, large scour hole near the structure may cause flow slide and then collapse of the caisson. It's related to stability failure of structure, so ω_j reading from Figure 11 should be 0.02. Since the failure mode is not piping, reading from Figure 12 a_j and b_j should be taken as 0.033 and 50, respectively. The total section length of the pumping station is $L=500$ m. After calculation, the new safety standard for the stability of pumping station is given as $1.50*10^{-6}$ annually.

$$N_j = 1 + \frac{a_j * L}{b_j} = 1 + \frac{0.033 * 500}{50} = 1.33$$

$$P_{req,i,j} = \frac{\omega_j}{N_j} * P_{req} = \frac{0.02}{1.33} * 10^{-4} = 1.5 \times 10^{-6}$$

Type of structure	Failure mechanism								Total
	Overflow or overtopping	Piping	Stability	Revetments	Dune erosion	Structure	Other	Reliability closure operation	
Dike	0.24	0.24	0.04	0.10	Na	0.08	0.30	Na	1.00
Structure	(0.24)	0.02	0.02	Na	Na	-	Na	0.04	0.08
Dune	Na	Na	Na	Na	0.70	Na	0.30	Na	1.00

Figure 11: Distribution of target reliability per failure mechanism

Failure mode	Location	$a_j [-]$	$b_j [m]$
Piping	Upper parts of the Rhine	0.9	300
	Other	0.4	300
Stability	All	0.033	50

Figure 12: Default parameters for determining the length-effect

Meanwhile, failure of the scour protection will not directly lead to collapse of the structure and also not the only cause of the collapse. The fault tree is given in Figure 13. The required failure probability of scour protection is the requirement for the design.

According to previous calculation, total required failure probability for collapse of the structure is $P_{collapse}=1.50 \cdot 10^{-6}$. Considering that the flow slide and erosion of foundation top layer have the same probability of causing the collapse, so $P_{slide}=P_{top}$. And filter erosion, due to better protection, has half the probability of occurrence $P_{filter}=0.5 P_{slide}$. With the 'or' gate, it gives that $P_{collapse}=P_{slide}+P_{top}+P_{filter}=2.5 P_{slide}$. The required failure probability for collapse caused by flow slide is $P_{slide}=6.02 \cdot 10^{-7}$ annually.

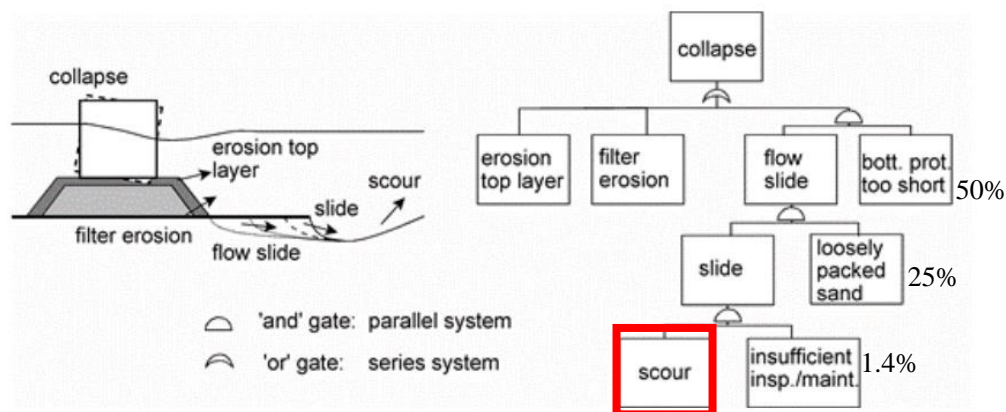

Figure 13: Fault tree of structure collapse (Schierck and Verhagen, 2016).

To get the required failure probability for scour protection, probability of insufficient maintenance, loosely packed sand base and short in scour protection need to be estimated.

When deciding the bottom protection length, factor n_s that is used is just an average value, so it's considered to be 50 % chance of a short bottom protection when flow slide happened (Leo, 2018). Since loosely packed sand is mostly to located near the tide channel and pumping station is relative far (Leo, 2018), the probability for loosely packed sand can be 25%. When there is failure of bed protection and scour happening, the heavy storm may lead to the maintaining unable to proceed. The scour hole takes few dozens of days to develop, so it is estimated that there is no sufficient maintainance if the storm is longer than 20 days. Based on the wave data, this probability is 1.4%.

Then the required failure probability for the scour protection at pumping station is then calculated as $P_{scour} = P_{slide} / (0.014 * 0.25 * 0.05) = 0.0015$. Based on Poisson distribution, the target return period is 2800 years.

For the spillway, a lower stability requirement should be applied, as it's sheltered in the flood protection. However without knowing the mechanism of how the failure of spillway is related to the failure of flood protection, same stability requirement is applied for spillway.

An overview of the stability requirement for scour protection at different part is listed in Table 1.

Table 1: Design requirement for different part

	Annual failure probability (P_f)	Failure probability within lifetime ($P_{f,TL}$)	Return period(R)
Tidal power plant	1/100	1	1
Pumping station	1/2800	1/28	2800
Spillway	1/2800	1/28	2800

2 Boundary condition

To obtain sufficient design for scour protection, the flow velocity pattern needs to be carefully determined at corresponding locations, while this process requires information about the hydraulic loads and the physical dimension of the structure.

2.1 Hydraulic conditions

2.1.1 Tide

The tide is generated by mutual gravitational attraction of the earth and the moon, as well as of the earth and the sun. The frequencies of the tide are governed by the well known movement of earth, moon and sun and are mainly diurnal and semi-diurnal. At the coast, the tide is most easily observed as daily water level variations.

The Rijkwaterstaat offers astronomical tidal data monitored from certain meteorological stations. For this project, Haringvliet 10 station, shown in Figure 14 is chosen as perfectly located at the area of interest. With records by the Haringvliet 10 station between March 1st 2018 and March 1st 2019, an overview of the astronomical tide at design location can be listed in Table 2.

The Maximum tidal range that causes head difference over the in-outlet will be taken into account for the design.

Table 2: Water level recorded by Haringvliet 10 station

Parameter	Value
Maximum tidal range(m)	2.99
Average tidal range(m)	2.11
Maximum high water level(m +NAP)	1.77
Average high water level(m +NAP)	0.53
Minimum high water level(m +NAP)	1.26
Maximum low water level(m +NAP)	-0.48
Average low water level(m +NAP)	-0.84
Minimum low water level(m +NAP)	-1.20

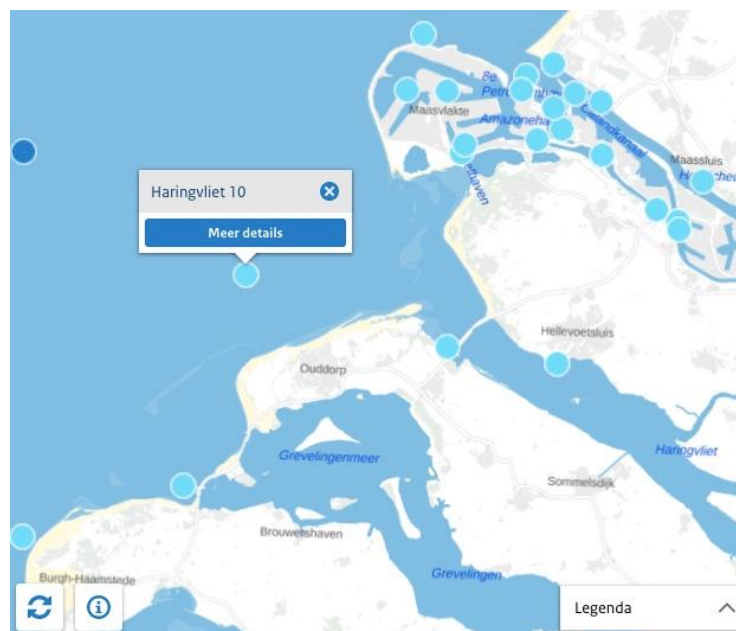

Figure 14: Location of Haringvliet 10 station (Rijkwaterstaat, 2019)

2.1.2 Sea level rise and land subsidence

Since the DELTA 21 project has a design functional time of 100 years, the effect of sea level rise and land subsidence needs to be considered for the design. According to the Veerman Committee, the sea level increase off the Dutch coast without considering land subsidence in 2050, 2100 and 2200 is shown in the Figure 15.

Consider the design lifetime, the aim is then to find the level of the sea by 2120 (Veerman Committee, 2008).

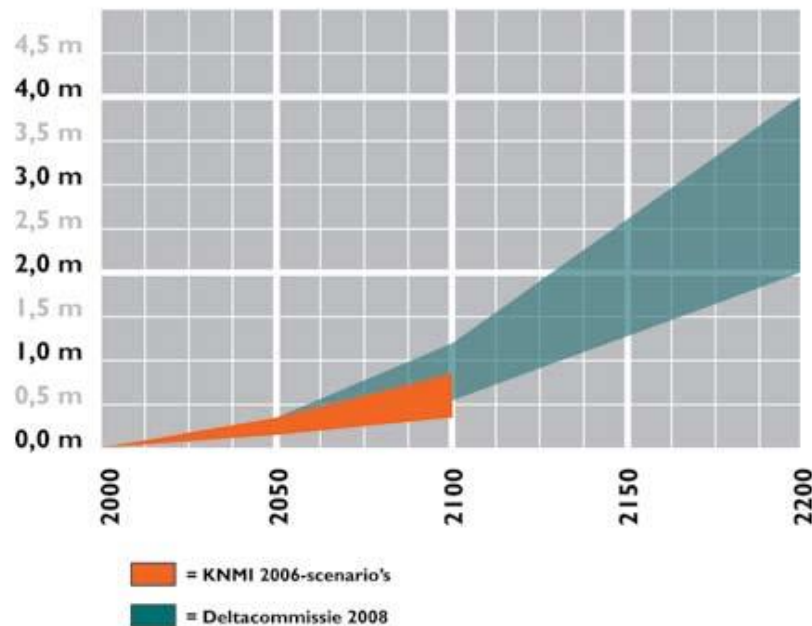

Figure 15: Sea level rise scenarios without land subsidence (Veerman Committee, 2008)

Follow the trend predicted by the Veerman Committee in 2008, the sea level rise by 2120 is expected to be 0.9-1.9 m. So here in this project, the sea level rise is estimated to be 1.4m. Meanwhile, the rate of land subsidence predicted by the Veerman Committee is 1.09mm/year. Therefore, by 2120 the subsidence is expected to be 10.9 cm. Combination of the sea level rise and the subsidence gives the overall relative sea level rise, which is 1.59 in 2120. The water level change considering relative sea level rise is listed in Table 3.

Table 3: Water levels expected in 2020

Parameter	Value
Maximum tidal range(m)	2.99
Average tidal range(m)	2.11
Maximum high water level(m +NAP)	3.36
Average high water level(m +NAP)	2.12
Minimum high water level(m +NAP)	2.85
Maximum low water level(m +NAP)	1.11
Average low water level(m +NAP)	0.75
Minimum low water level(m +NAP)	0.38

High water level correspond to higher significant wave height that can be propagated to the design location. Larger wind set-down is instead, related to low water level, which is also kind of source for larger head difference. Therefore, the design water level in this project is chosen based on the contribution of different physical marine processes on the driving force of failure. So, for the velocity pattern calculation at

different parts of the structure, scenarios of water level with relative sea level rise (higher water levels) and average water level without relative sea level rise (lower water levels) will both be checked to find the most unfavorable load combination.

2.1.3 Wave

Certain wave condition can be threaten for the stability of the scour protection at seaside. So the wave condition among the interested area will be studied based on offshore data from website of Waveclimate and onshore transport simulation of SwanOne.

The Waveclimate website provides site-specific and detailed information on the offshore wind and wave climate. Wave and wind data for this project is gathered at the offshore location $52^{\circ} 01'N$, $3^{\circ} 50' E$ between 1992 to 2014. To obtain the design wave condition, extreme value analysis is done based the data of 23 years. The calculation result given in Appendix A and result of Figure 17 shows that the significant wave height best fits in a Weibull distribution and has two main directions of 340° and 260° .

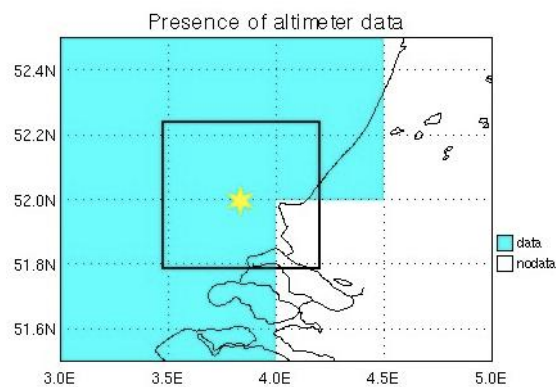

Figure 16: Offshore location for wave data (Waveclimate, 2019)

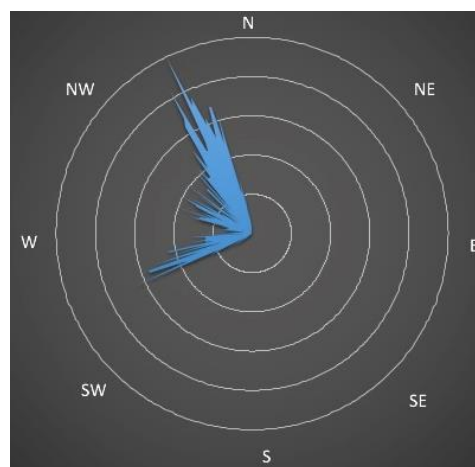

Figure 17: Wave direction rose

Significant wave height of return period 1 and 2800 years can be calculated based on the distribution obtained from extreme value analysis, result is given in Table 4. The calculation is given in Appendix A.

Table 4: Design storm wave height and wave period predictions

Direction	340°		260°	
Return period(years)	1	2800	1	2800
Hs(m)	3.976	8.128	3.603	7.213

Combine with four different water levels, high and low tide with sea level rise as well as high and low tide without sea level rise, 16 typical wave conditions are propagated from offshore location to the onshore location if the gate. Also The depth contour is read from webapp.navionics.com and listed in Appendix B. The location of the inlet for Valmeer and Getijmeer is around the bottom elevation of NAP -10m, the output of onshore wave condition is reading at that point.

The wave period T_p used in SwanOne simulation is asstimated by the correlation between wave height and wave period, which is the result of linear fitting of storm data. The result is given as $T_p = 4.01\sqrt{H_s}$ for wave coming from 260° and $T_p = 4.85\sqrt{H_s}$ for wave coming from 340°. The corresponding wind speed U_{10} is based on fully developed sea state, which is given as $U_{10} = \sqrt{gH_{m0} / 0.24}$ (Ocean wave).

Simulation result included in table 5.

Table 5: Wave condition at offshore and onshore location

Direction	Return period(yrs)	Water Level (m +NAP)	Offshore			Onshore			
			U_{10} (m/s)	H_s (m)	T_p (s)	H_s (m)	T_{m0} (s)	Direction	Setup(m)
340°	1	2.12	12.75	3.976	9.662	3.63	7.22	11.13°	0.01
	2800	2.12	18.23	8.128	11.43	5.24	7.34	16.80°	0.07
260°	1	2.12	12.14	3.603	9.20	2.46	5.66	323.36°	0.003
	2800	2.12	17.17	7.213	13.02	4.54	8.02	333.26°	0.021
340°	1	0.53	12.75	3.976	9.662	3.71	6.59	10.70°	0.01
	2800	0.53	18.23	8.128	11.43	4.53	7.06	16.10°	0.107
260°	1	0.53	12.14	3.603	9.20	2.47	6.23	326.78°	0.005
	2800	0.53	17.17	7.213	13.02	4.06	7.30	335.27°	0.043
340°	1	0.75	12.75	3.976	9.662	3.71	6.67	10.77°	0.001
	2800	0.75	18.23	8.128	11.43	4.62	7.08	16.17°	0.103
260°	1	0.75	12.14	3.603	9.20	2.48	6.24	326.56°	0.005
	2800	0.75	17.17	7.213	13.02	4.07	7.45	334.63°	0.041
340°	1	-0.84	12.75	3.976	9.662	3.64	6.10	10.61°	0.003
	2800	-0.84	18.23	8.128	11.43	3.96	6.54	13.92°	0.135
260°	1	-0.84	12.14	3.603	9.20	2.48	6.06	328.16°	0.002
	2800	-0.84	17.17	7.213	13.02	3.69	6.99	337.20°	0.086

Further more, to analysis the effect of wave propagated from direction of 340° N at the target location, sheltering of the Valmeer needs to be considered. The diffraction result change in wave height and wave period. The height ratio and period ration is given in *Rock manual*. Figure 18 gives the diffraction diagram for the case of wind wave ($S_{max}=10$) perpendicular to the semi-infinite breakwater. Wave from 340° N is considered to be roughly normal incidence for the northern barrier. Reading form the diagram, the height is reduced with a ratio of 0.7 and wave period stays constant. Then actual wave height and wave period after diffraction for wave from 340° N is listed in Table 6.

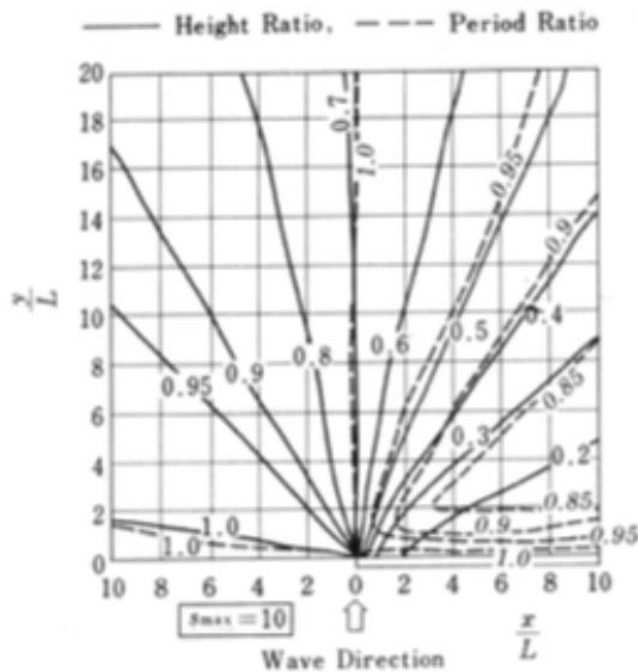

Figure 18: Diffraction diagram for semi-infinite breakwater for random wave of normal incidence.(CIRIA, 2007)

Table 6: Wave height and wave period after diffraction(Wave from 340° N)

Return period(yrs)	Water Level (m +NAP)	Tp(s)	Hs(m)
1	2.12	7.22	2.54
2800	2.12	7.34	3.66
1	0.53	6.59	2.59
2800	0.53	7.06	3.17
1	0.75	6.67	2.59
2800	0.75	7.08	3.23
1	-0.84	6.10	2.54
2800	-0.84	6.54	2.77

2.1.4 Wind

Wind blow in the shallow tidal lake Getijmeer can lead to wind setup and set-down, which will further increase the head difference over the tidal power plant. While for Valmeer with large water depth, wind setup is limited and the largest velocity at the in-outlet is only decided by the pumping capacity, so wind setup is not considered.

Wind speed U_{10} of certain return period is calculate in the way discussed in wave analysis, which is proportion to the square root of offshore significant wave height. Another factor that largely effect the wind set is angle between the wind direction and normal direction of the barrier. The Windfinder website offers wind direction distribution based on observation from August 1999 to May 2019. Based on measurements from Station Hoek van Holland, it can be seen that the wind is mainly distributed over SSW to W.

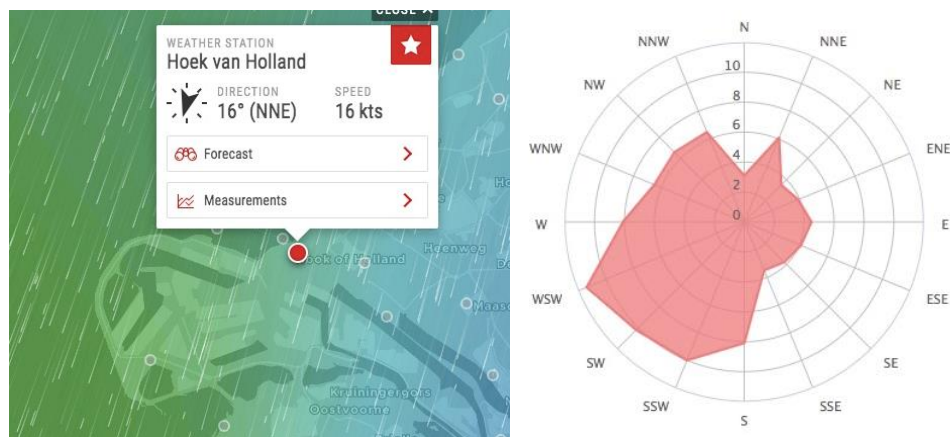

Figure 19: Location of Hoek van Holland and wind direction distribution (Windfinder, 2019)

Since the normal direction of the tidal barrier is around WSW, it can be estimated that the wind mainly comes from WSW and is perpendicular to the tidal barrier, causes largest wind set down over the tidal power plant.

For the design of the bed protection of tidal power plant and near the spill way will be affected by the wind set-down, so the wind speed with a return period of 1 and 2800 years will be checked considering different water level in Getijmeer. The wind set-down is calculated with following formula.

$$Z_w = 0.5 * \kappa \frac{U_{10}^2}{gh} * F \cos(\varphi)$$

Where:

Z_w = Wind set up[m]

$\kappa=3.5*10^{-6}$ [-]

U_{10} =Wind speed[m/s]

F=Fetch[m].

h =Average depth of the tidal lake[m]. Estimated to be 2m

Reading from the depth contour (Figure 21) and layout with measurement (Figure 20), the fetch of the Getijmeer F is estimated to be 10 km and the average water depth h is 2m with water level as 0m +NAP. The result of wind set-down in Getijmeer is shown in table 7.

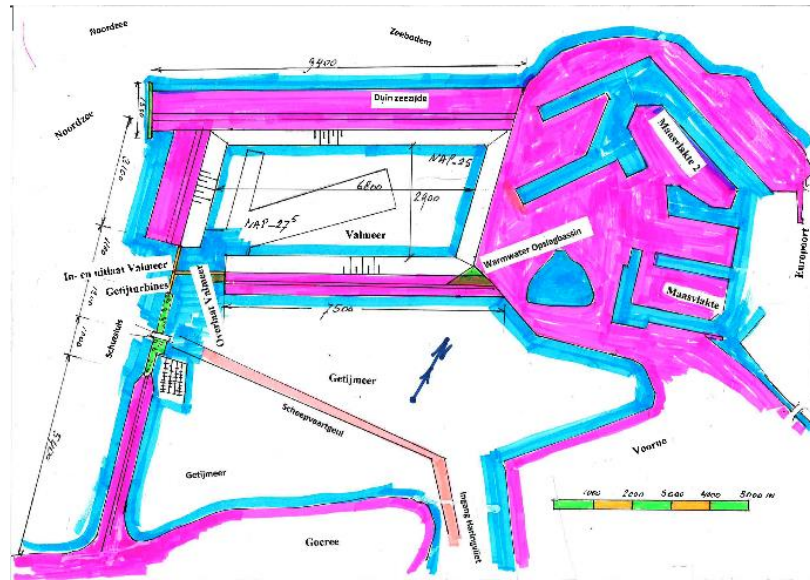

Figure 20: Layout of the DELTA 21 project (Berke and Lavooij, 2018)

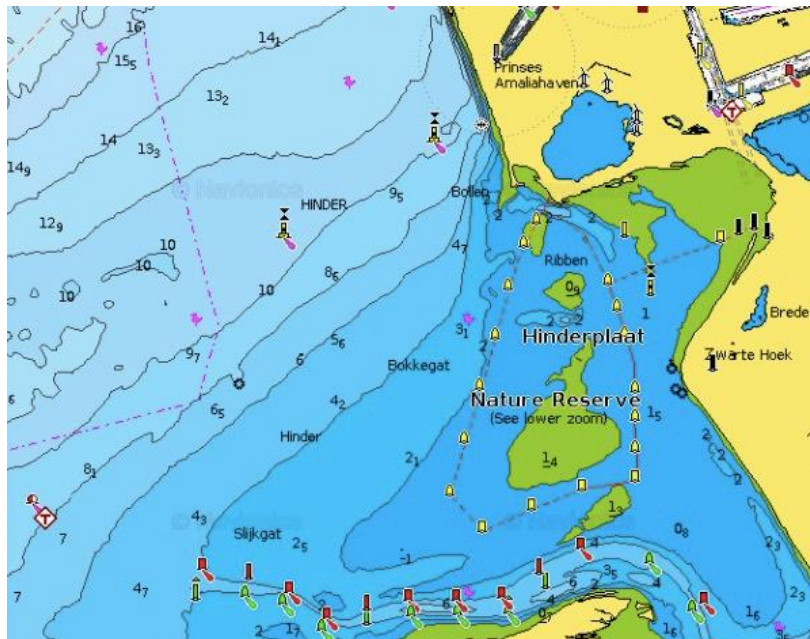

Figure 21: Depth contour at the location of Valmeer (Navionics, 2019)

Table 7: Wind set-down calculation

Water level(m +NAP)	Water depth h(m)	Return period	Wind speed U ₁₀ (m/s)	Wind set-down Z _w (m)
-0.84	1.16	1	12.14	0.06
		2800	17.17	0.37
0.75	2.75	1	12.14	0.09
		2800	17.17	0.16
0.53	2.53	1	12.14	0.10
		2800	17.17	0.17
2.12	4.12	1	12.14	0.06
		2800	17.17	0.10

2.2 Geological setting

The scour protection is meant to prevent the lose of subsoil, so the information of the subsoil at the project location is vital. The DINOLOket portal provides extensive data from the Dutch subsurface through many analyses of borehole measurements and drilling profiles.

From the geological drilling survey B36H0170 and BS030046, a drill sample profile and grain size analyses can be retrieved. In the depth range of 0m to 11m relative to the surface level, the subsoil material property is shown to be medium category sand.

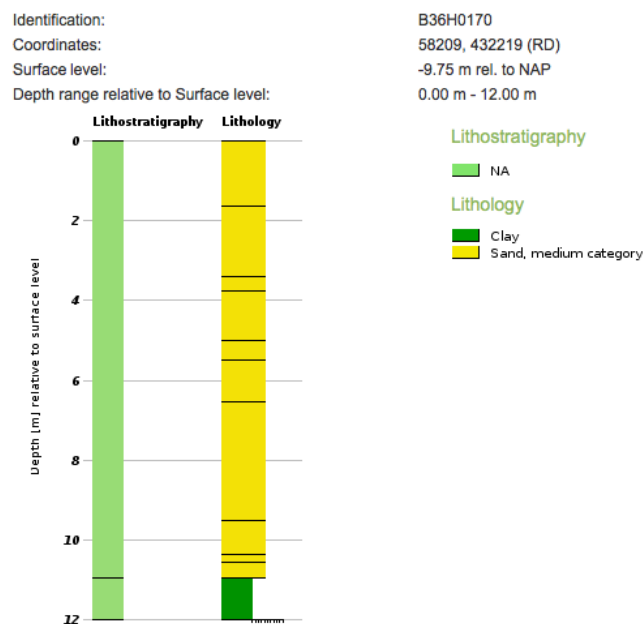

Figure 22: Borehole log profile of subject area (Netherlands Organization for Applied Natural Sciences Research TNO, 2019)

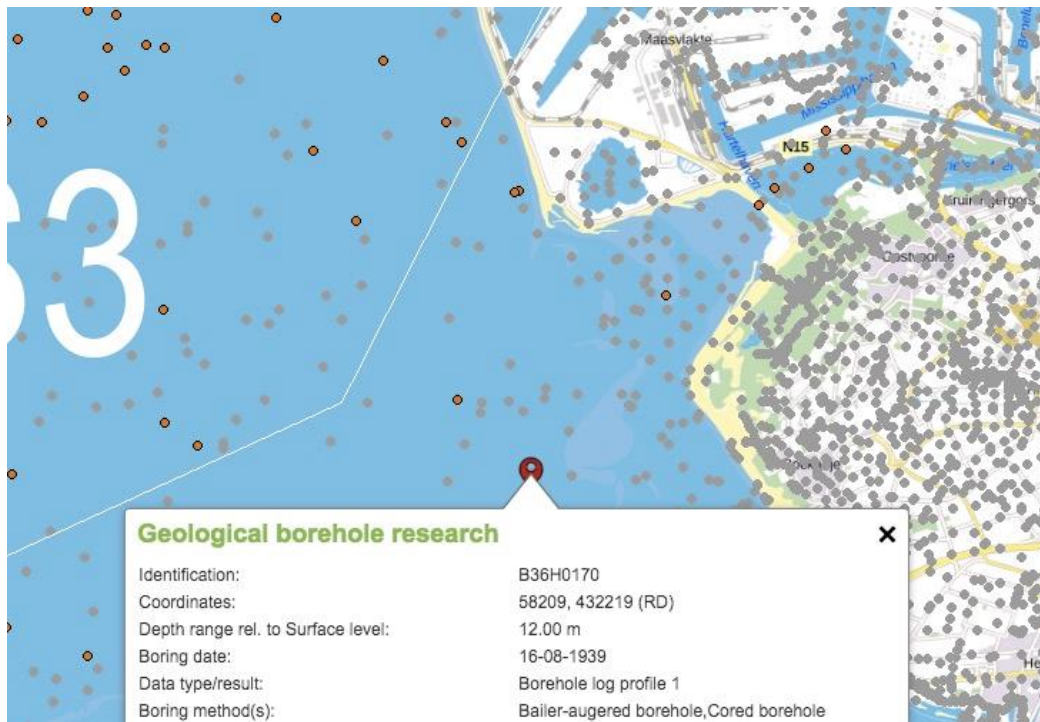

Figure 23: Location of geological drilling survey B36H0170(Netherlands Organization for Applied Natural Sciences Research TNO, 2019)

From the grain size analyses, it can be known that the soil is mainly composed of sand and the particle diameter is distributed between 0.05mm to 2mm. Also the figure gives that for the base material d_{n50} lies around 0.2, which is crucial for the scour protection design.

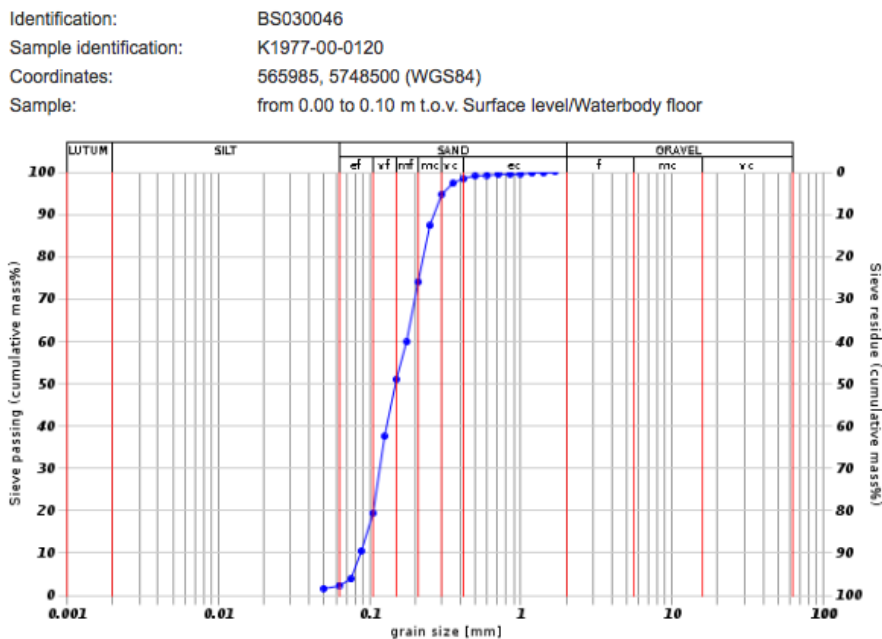

Figure 24: Grain size distribution of the first subsoil meter (Netherlands Organization for Applied Natural Sciences Research TNO, 2019)

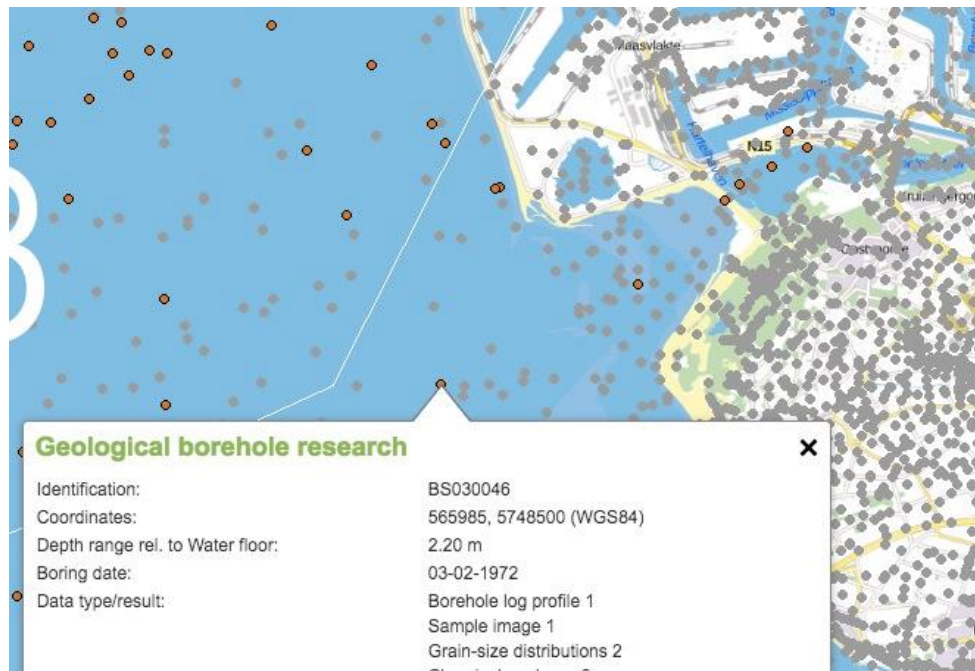

Figure 25: Location of geological drilling survey B36H0170(Netherlands Organization for Applied Natural Sciences Research TNO, 2019)

3 Scour protection design

With boundary condition developed, technical design of the scour protection will be done in this chapter. To start with, proper bed protection type needs to be decided for the DELTA 21 project.

It is chosen to implement a granular filter over a geotextile filter. The reason behind this choice is that, placing of geotextiles under water is quite complex due to current flow and wave motion. Also, dumping stone can lead to damage to geotextile, so the fall-height during dumping of stones is quite limited.

Further more in this case, a geometrically closed filter is preferred then open filter. Since at the location of the bed protection turbulence is existed. This will lead to flow in vertical direction, which makes a geometrically closed filter more applicable for this case.

3.1 Flow pattern calculation

To make the scour protection design, flow pattern at the target location needs to be studied. Since in this case, flow at the target location is not uniform flow, the property of the flow needs to be known. With different factors influencing the flow, for each

part of the design, it is essential to find the most dangerous condition with maximum flow velocity near the bed, which is the design condition for the scour protection.

For all the structure considered in this case, including tidal power plant, pumping station and spillway, current flow at the outlet is kind of jet flow. In *Introduction to Bed, bank and shore protection*, Schiereck clearly demonstrated how the jet flow is developed after the outlet and the distribution of turbulence in the flow, shown in Figure 26.

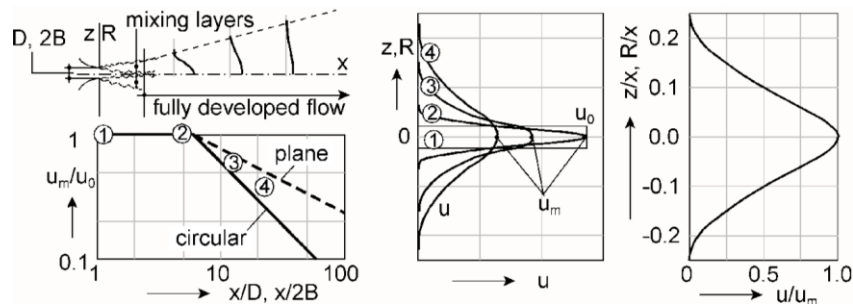

Figure 26: Flow, velocities and turbulence in mixing layer (Schiereck and Verhagen, 2016)

Formed by two mixing layers, flow velocity at the centre-line is at first stay constant and start to decrease after the flow is fully developed. The following expression are for flow velocity at central line of the jet flow, but only valid in the region of fully developed flow. For plane jets, it starts at about $x=12B$ (B is half the width of the orifice) and $x=6D$ for circular jets (D is the radius of the orifice).

$$\text{Plane jets : } u_m = \frac{3.5u_0}{\sqrt{x/B}}, b = 0.1x, u = u_m e^{(-0.693(\frac{z}{b})^2)}$$

$$\text{Circular jets : } u_m = \frac{6.3u_0}{x/D}, b = 0.1x, u = u_m e^{(-0.693(\frac{R}{b})^2)}$$

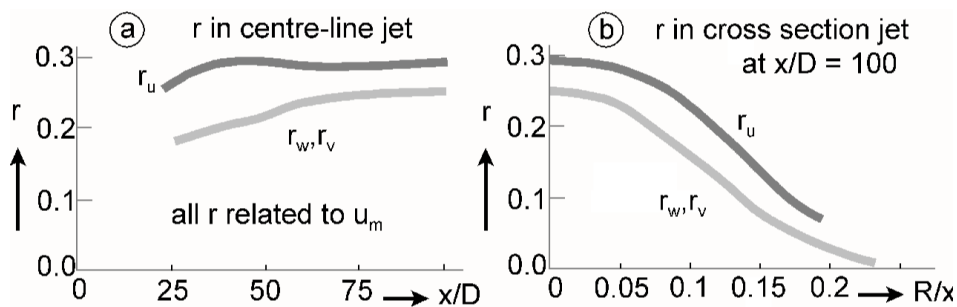

Figure 27: Turbulent fluctuations in circular jet (Schiereck and Verhagen, 2016)

The fluctuation shown in Figure 27 is relative to the velocity u_m , the maximum velocity in the center-line. The relative fluctuation becomes constant in the center-line with a value of 0.3 and decreases as away from the center-line. With largest mean

flow velocity and largest turbulence, flow at the jet flow center-line matters for the scour protection design.

The property of jet flow just describes the development of current. For the water motion caused by wave effect near the bed stay constant in the area.

3.1.1 Tidal power plant

To design the scour protection for the tidal power plant, the combine effect of sea level rise, wave, tidal range, river discharge and wind set-down needs to be checked. For both the scour protection at the seaside and lakeside, to find the most dangerous condition, 8 different scenarios are analysed.

Scenario 1: Without sea level rise, low tide at seaside and high tide inside Getijmeer, no large discharge from river

Scenario 2: Without sea level rise, high tide at seaside and low tide inside Getijmeer, no large discharge from river

Scenario 3: With sea level rise, low tide at seaside and high tide inside Getijmeer, no large discharge from river

Scenario 4: With sea level rise, high tide at seaside and low tide inside Getijmeer, no large discharge from river

Scenario 5: Without sea level rise, low tide at seaside and high tide inside Getijmeer, with 4000 m³/s discharge from river

Scenario 6: Without sea level rise, high tide at seaside and low tide inside Getijmeer, with 4000 m³/s discharge from river

Scenario 7: With sea level rise, low tide at seaside and high tide inside Getijmeer, with 4000 m³/s discharge from river

Scenario 8: With sea level rise, high tide at seaside and low tide inside Getijmeer, with 4000 m³/s discharge from river

Flow caused by head difference

The head difference over the tidal power plant is mainly decided by the maximum tidal range and also effected by the wind set-down in Getijmeer. When there is low tide in Getijmeer, the head difference will be the maximum tidal range 2.99m plus the wind set-down. While, it will be minus if its high tide in Getijmeer.

The placed turbine, due to friction and turbulence will lead to a reduction to flow rate caused by the head diefference. The *Conceptual Design and Comparison of Two Propeller Turbine Configurations* (Meijnen & Arnold, 2015), gives a description of calculation the reduction rate. Figure 28 presents a schematic representation of a water-turbine guide current. The turbine with rotor surface A_r is placed in or behind a channel or passage opening with a cross-sectional area A_s , the flow velocity being determined by the prevailing pressure difference H .

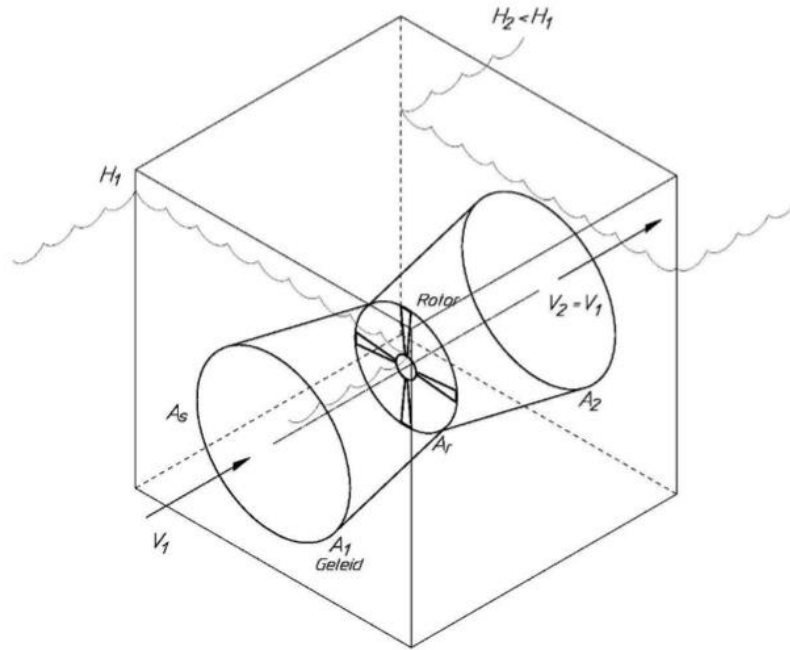

Figure 28: Schematic presentation of a direct current turbine (Meijnen & Arnold, 2015)

For a conduction current turbine, $h_2 < h_1$ and $v_2 = v_1$. The discharge caused by the head difference H in this condition is given as follow.

$$Q = A_s \sqrt{\frac{2g(|H| - H_r)}{C}} = A_s \sqrt{\frac{2g|H|(1 - f)}{C}}$$

Where:

$|H|$ = the head difference over the placed turbine

H_r = the energy added or withdrawn by the rotor

C = the loss coefficient due to friction and turbulence in the passage opening

f = the degree of reaction of the turbine (0 – 1)

From their research, Meijnen and Arnold gather that for the maximum power $f = 2/3$. The loss coefficient C is varied for different setups, a ducted setup $C_{ducted} = 1.25$ and a venturi setup $C_{venturi} = 1.35$. Without decided design scheme, in this case the flow rate is calculated with lower loss coefficient, so $C = C_{ducted} = 1.25$. Combine with the equation:

$$Q = vA_s$$

The average flow rate at the in-outlet caused by the head difference is then calculated as:

$$u_h = \sqrt{\frac{2g|H|(1-f)}{C}}$$

Flow caused by river discharge

Also when there is large water discharge from the river, the tidal power plant can also allow maximumly 4000 m³/s discharge through the in-outlet. The flow rate due to this discharge can then be calculated as :

$$u_d = \frac{Q_{max}}{A_s}$$

As mentioned before, the tidal power plant is composed of 40 turbines with a 10 meters growing width. So the area of cross section is given as:

$$A_s = 40 * \pi * 5^2 = 3140 \text{ m}^2$$

$$u_d = \frac{Q_{max}}{A_s} = \frac{4000}{3140} = 1.27 \text{ m/s}$$

The discharge is always release towards the sea. So, when its high tide in Getijmeer, the current induced by the tidal range has the same direction with the discharge flow. When its low tide in Getijmeer, it holds the opposite direction.

Velocity caused by wave motion

The scour protection at the sea side will also be effected by series wave attack. According to the linear wave theory, wave can lead to orbital motion of the fluid particales. So near the bed, horizontal particle velocity will contribute to the movement of sand grains. This velocity can be calculated based on equations from linear wave theory:

$$\lambda = \frac{g}{2\pi} T^2 \tanh \frac{2\pi d}{\lambda}$$

$$u = \omega a \frac{\cosh k(z+d)}{\sinh kd} \sin(\omega t - kx)$$

Where λ is the wave length, d is the water depth, z is the vertical coordinate and at the bed z+d equals to 0. Since the maximum velocity at the bottom is the relevant velocity, the sine function equals 1 and with amplitude a taken half of the wave height, the formula develops to:

$$u_{w,max} = \frac{\omega a}{\sinh kd}$$

Maximum velocity at Getijmeer side

The current velocity which is also the maximum velocity at Getijmeer side, is calculated as

$$u_c = u_{tidal,Getijmeer} = u_h \pm u_d$$

With the equations and methods known, the result of calculation is given in table 8. From the result, it can be known that scenarios 7 holds the largest flow rate at the Getijmeer side cross section, and which is set to be the design condition for scour protection of the tidal power plant at Getijmeer side.

Table 8:Flow velocity of different scenarios at Grtijmeer side cross section.

	Tidal range a(m)	Wind set-down Δh_w (m)	Head difference Δh (m)	u_h (m/s)	u_d (m/s)	$u_c=U_{tidal,Getijmeer}$ (m/s)
Scenario 1	2.99	0.09	2.90	3.89	0	3.89
Scenario 2	2.99	0.23	3.22	4.10	0	4.10
Scenario 3	2.99	0.06	2.93	3.91	0	3.91
Scenario 4	2.99	0.10	3.09	4.02	0	4.02
Scenario 5	2.99	0.09	2.90	3.89	1.27	5.16
Scenario 6	2.99	0.23	3.22	4.10	1.27	2.83
Scenario 7	2.99	0.06	2.93	3.91	1.27	5.18
Scenario 8	2.99	0.10	3.09	4.02	1.27	2.75

Maximum velocity at sea side

At the sea side, velocity near the bed is much complicated. The total maximum flow velocity at the bottom then becomes the sum of the current velocity u_h and u_d combine with the velocity due to wave motion $u_{w,max}$ taking into account the angle between the two motions. The max velocity near the bed at sea side is calculated as:

$$u_{tidal,sea} = \sqrt{(u_h \pm u_d + u_{b,max} \cos(\alpha))^2 + (u_{b,max} \sin(\alpha))^2}$$

Where α is the angle between direction the current flow and the wave motion. Wave from 260° N is considered perpendicular to the tidal barrier and $\alpha=0^\circ$ and then $\alpha=80^\circ$ from wave from 340° N.

For different scenarios, this velocity is calculated and listed in table 9. Under scenario 5, wave propagated from 260° causes the maximum velocity near the bed. So characters of scenario 5 combine with wave from 260° will be the design condition for scour protection of tidal power plant at the sea side.

Table 9:Flow velocity near the bed of different scenarios at seaside cross section.

	u_c (m/s)	$u_{w,max}$ (m/s)		Angle between current and wave α ($^\circ$)		$u_{tidal,sea}$ (m/s)	
		340°	260°	340°	260°	340°	260°
Scenario 1	3.89	1.39	1.07	80	0	4.13	4.96
Scenario 2	4.10	1.36	0.96	80	0	4.32	5.07
Scenario 3	3.91	1.05	0.97	80	0	4.05	4.89

Scenario 4	4.02	0.96	0.83	80	0	4.14	4.85
Scenario 5	5.16	1.39	1.07	80	0	5.34	6.23
Scenario 6	2.83	1.36	0.96	80	0	3.14	3.80
Scenario 7	5.18	1.05	0.97	80	0	5.29	6.16
Scenario 8	2.75	0.96	0.83	80	0	2.92	3.58

3.1.2 Pumping station

As mentioned before, for the pumping station only the scour protection at seaside is designed in this case. So, only the flow pattern at the seaside is interested. Near the bed the maximum velocity is also the combination of the current flow and wave motion. Also considering the effect of sea level rise, there is 4 scenarios to be considered.

Scenario 1: Without sea level rise, low tide at seaside

Scenario 2: Without sea level rise, high tide at seaside

Scenario 3: With sea level rise, low tide at seaside

Scenario 4: With sea level rise, high tide at seaside

The current flow is decided by the 10,000 m³/s discharge of the pumping station under extreme condition. It is calculated as

$$u_d = \frac{Q_{max}}{A_s}$$

$$A_s = Ld$$

Where L=500 m is the length of the pumping station, d is the water depth, which varies in different scenarios.

The wave motion near the bed is calculated in the same way as the tidal power plant. But for the design of scour protection at pumping station, the incoming wave has a return period of 450 years. Then the maximum velocity near the bed is calculated as:

$$u_{pump} = \sqrt{(u_d + u_{b,max} \cos(\alpha))^2 + (u_{b,max} \sin(\alpha))^2}$$

Table 10: Flow velocity near bed at the pumping station

	Water level (m+NAP)	Water depth d (m)	u _d (m/s)	u _{w,max} (m/s)		α(°)		U _{pump} (m/s)	
				340°	260°	340°	260°	340°	260°
Scenario 1	-0.84	9.16	2.18	1.22	1.56	80	0	2.50	3.75
Scenario 2	0.75	10.75	1.86	1.36	1.64	80	0	2.30	3.50
Scenario 3	0.53	10.53	1.90	1.30	1.62	80	0	2.30	3.52
Scenario 4	2.12	12.12	1.65	1.43	1.62	80	0	2.18	3.27

According to the result, scenario 1 combine with wave from 260° N, should be the design condition for the scour protection at pumping station.

3.1.3 Spillway

The spillway is sheltered in the flood protection and the flow pattern over this region is only decided by the extreme discharge, which is equal to the maximum discharge of pumping station as 10,000 m³/s.

$$u_{spillway} = u_d = \frac{Q_{max}}{A_s}$$

$$A_s = Ld$$

Where the total length of the spillway L is 360 m, water depth d is effected by tide and wind set-down. To get the maximum velocity, the lowest water depth is needed. This can be achieved when sea level rise is not included and low tide in Getijmeer, also wind set-down holds the maximum value under this condition and further decreases the water depth. So the former condition is set to be the design condition for scour protection near spillway. Then the minimum water depth is given as

$$d_{min} = d - \Delta h_w = 9.16 - 0.37 = 8.79m$$

The maximum flow velocity then is

$$u_{spillway} = \frac{Q_{max}}{Ld} = \frac{10,000}{360 \times 8.79} = 3.16 m/s$$

3.2 Armour layer design

The design of scour protection will start with the armour layer, and the filter is built up based on the armour stone and subsoil. The scour protection needs to have sufficient length to avoid the influence of the stable scour hole at the end of the bed protection, and sufficient amour stone size to get a stable bed protection.

The required length of the bottom protection is calculated with:

$$L \geq \gamma n_s h_{max}$$

where:

γ = Safety factor (>1.0) [-]

n_s =The average slope of the slide [-]

h_{max} =The maximum scouring depth [m]

The average slope of the slide is 6 for densely packed material and 15 for loosely packed material (Molenaar and Voorendt). Since in the previous calculation of safety standard, the base material is treated as loosely packed and probability for the bed bed

protection to have an insufficient length is set to be very small. So in this project, n_s equals to 15.

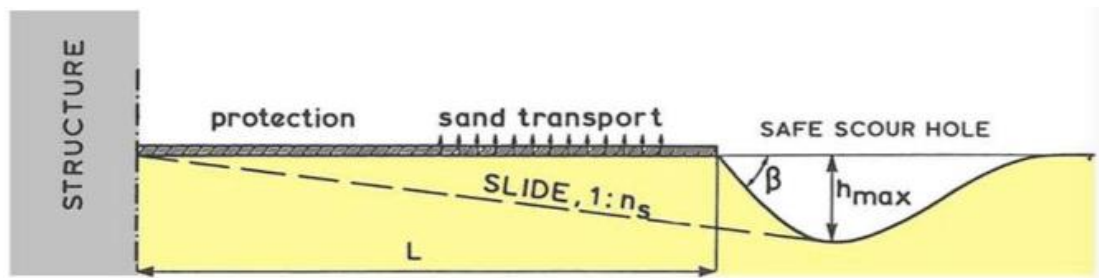

Figure 29: Length of bottom protection (Molenaar and Voorendt)

For a scouring process, the maximum or equilibrium scour depth is given as:

$$\frac{h_{max}}{h_0} = \frac{(0.5 * \alpha * u) - u_c}{u_c} \text{ for } (0.5 * \alpha * u) - u_c > 0$$

Where:

h_0 = the initial water height [m]

h_{max} = the maximum scouring depth (the equilibrium depth) [m]

u = the depth-averaged flow velocity at the end of the bed protection [m/s]

u_c = the critical velocity regarding begin of motion of sand particles [m/s]

α = a coefficient to include turbulence effects. The value of α is in the order of 3 [-]

The critical velocity u_c can be calculated with Shields equation:

$$u_c = C \sqrt{\psi_c \Delta D_{n50}}$$

$$C = 18 * \log \left(12 \frac{h}{k_r} \right)$$

Where:

D_{n50} = the median nominal diameter of sand particles [m]

C = Chézy coefficient [$\sqrt{m/s}$]

k_r = the equivalent bed roughness. [m]

$k_r \approx 2D_{n50}$ for narrowly graded gravel and rock

$k_r \approx 3D_{n90} \approx 6D_{n50}$ for widely graded gravel and rock

$k_r \approx 1$ to 5 dm for sand which is the height of the bed form

Δ = the relative density [-]

ψ_c = Shields parameter [m]

It's notable that, to get the maximum scour depth, velocity at the end of the bed protection is needed, which is effected by the length of scour protection due to the property of jet flow. So, iterative calculation is used to get the final required bed protection length.

For the calculation of the armor layer, two approaches can be applied: Izbash and Shields. There two approach is suitable for different condition and are compared in Table 11.

Table 11: Comparison of Izbash and Shields method

Izbash	Shields
Large stones in shallow water (low h/d)	Large stones in shallow water (low h/d)
Flow type: Non-uniform	Flow type: Uniform (correction possible)
Consider individual rocks	Does not consider individual grains
$d_n = \frac{0.7\Delta u^2}{2g}$	$d_{n50} = \frac{K_v^2 u^2}{K_s \psi_c \Delta C^2}$

In this case, to deal with the stability of entire armour layer in 10 m deep water, it's obvious that Shield is preferred. Therefore, Shields is used to decide the armour stone size. Shields parameter is actually developed from uniform flow condition, but can be used under turbulent flow by introducing two correction factor.

$$C = 18 \log \left(\frac{12h}{k_r} \right)$$

The Chezy value is given by Nikuradse-Colebrook. K_s is the slope correction factor, here in this condition equal to 1. While K_v is correction factor is related to turbulence intensity r.

$$K_v = \frac{1 + 3r}{1 + 3r_{cu}}$$

At the center-line, turbulence density is $r=0.3$, and for uniform flow $r_{cu}=0.11$, which gives the correction factor $K_v=1.43$.

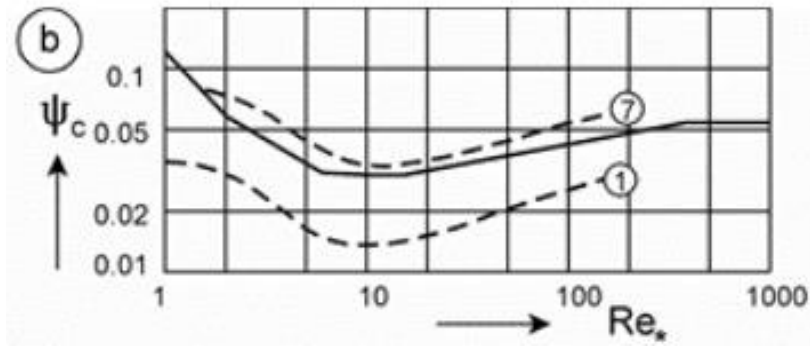

Figure 30: Shields parameter and different transport stage (Schierreck and Verhagen, 2016)

Shields parameter stands for transport stages of particles, with higher value stands for more movements, shown in Figure 30. $\psi_c = 0.04$ is related to the stage of movements of particles happens at some location and $\psi_c = 0.055$ is general movements of the entire surface. So for the design of scour protection at tidal power plant, $\psi_c = 0.04$ is considering SLS condition. While, $\psi_c = 0.055$ is used under ULS condition for the design at pumping station and spillway and stands for the total failure of the bottom protection.

There is a progressively decreasing of the stone size in the direction of away from the orifice. Flow caused by head difference and water discharge is decelerated due to the development of jet flow. At the sea side, this reduced velocity is further combined with the wave effect. In this case the wave motion is in the same direction with the jet flow, so the velocity is given as:

$$\text{Sea side: } u = u_x + u_w$$

$$\text{Getijmeer side: } u = u_x$$

Where:

u = velocity at location x . [m/s]

u_x = jet flow velocity at location x . [m/s]

u_w = flow velocity due to wave motion. [m/s]

These equations gives the analytical value for the required stone size. At last, the armour stone is chosen from the standard gradings and blocks to meet the requirement.

3.2.1 Tidal power plant

Armour stone size and scour protection is decided separately at sea side and Getijmeer side for tidal power plant. Flow at the tidal power plant is circular jet flow and the radius of the turbine orifice is $D=5\text{m}$.

Sea side

According to previous calculation, the design condition is without sea level rise, low tide at seaside and with 4000 m³/s discharge from river. Water depth at low tide without sea level rise is h=9.16m. For the base material, it's medium sand with D_{n50}=0.2 mm. For a sandy base, the equivalent bed roughness k_r is taken as 1 dm.

The Chezy value for the at with initial base material is given as:

$$C = 18 * \log \left(12 \frac{R}{k_r} \right) = 18 * \log \left(\frac{12 * 9.16}{0.1} \right) = 54.74$$

The critical flow velocity can be calculated as:

$$u_c = C \sqrt{\psi_c \Delta D_{n50}} = 54.74 * \sqrt{0.055 * 1.65 * 0.0002} = 0.233 \text{ m/s}$$

After iterative calculation, the final scour protection length is set to be 1050 m at sea side for the tidal power plant.

According former calculation, the jet flow velocity just at the orifice is u₀= 5.16 m/s, and velocity of wave motion is u_w= 1.07 m/s. The velocity at the end of the bed protection is:

$$u = u_x + u_w = \frac{6.3u_0}{x/D} + u_w = \frac{6.3 * 5.16}{1050/5} + 1.07 = 1.218 \text{ m/s}$$

The equilibrium scour depth can be calculated :

$$h_{max} = \left(\frac{(0.5 * \alpha * u) - u_c}{u_c} \right) * h_0 = \left(\frac{0.5 * 3 * 1.218 - 0.233}{0.233} \right) * 9.16 = 63.00 \text{ m}$$

With safety factor $\gamma = 1.1$, n_s=15, the scour protection is given as:

$$L \geq \gamma n_s h_{max} = 1.1 * 15 * 63.00 = 1039.54 \text{ m}$$

So a 1050 m is a sufficient length for the scour protection.

To save cost, different armour stone size is applied at different section by calculating velocity at different distances. The Shields equation is solved to get the theoretical value of D_{n50} for armour stone. A certain stone class is chosen from Standard grading in EN13383 to meet the requirement and the layer thickness is decided. At the sea side of the pumping station, the armour layer design is listed in Table 12.

Table 12: Armour layer design at sea side of the tidal power plant.

Distance from orifice x (m)	Velocity u (m/s)	Theoretical value of Dn50 (mm)	Armour stone class	Practical value of Dn50 (mm)	Layer thickness t(mm)
0-55	6.23	1383	HMA6000-10000	1440	2160
55-120	4.03	491	HMA300-1000	590	880
120-200	2.42	114	CP90/250	128	200
200-1050	1.88	52	CP45/125	64	200

Getijmeer side

At the Getijmeer side, the design condition is with sea level rise, low tide at seaside and high tide inside Getijmeer, and with 4000 m³/s discharge from river. Water depth h=12.06 m.

The Chezy value for the at with initial base material is given as:

$$C = 18 * \log\left(12 \frac{R}{k_r}\right) = 18 * \log\left(\frac{12 * 12.06}{0.1}\right) = 56.88$$

The critical flow velocity can be calculated as:

$$u_c = C \sqrt{\psi_c \Delta D_{n50}} = 56.88 * \sqrt{0.055 * 1.65 * 0.0002} = 0.242 \text{ m/s}$$

The bed protection length after calculation is 360 m, calculation is shown as follow. The jet flow velocity just at the orifice is u₀= 5.18 m/s. The velocity at the end of the bed protection is:

$$u = u_x = \frac{6.3u_0}{x/D} = \frac{6.3 * 5.18}{380/5} + 1.07 = 0.435 \text{ m/s}$$

The equilibrium scour depth can be calculated :

$$h_{max} = \left(\frac{(0.5 * \alpha * u) - u_c}{u_c}\right) * h_0 = \left(\frac{0.5 * 3 * 0.435 - 0.242}{0.242}\right) * 9.16 = 21.77 \text{ m}$$

With safety factor $\gamma = 1.1$, $n_s=15$, the scour protection is given as:

$$L \geq \gamma n_s h_{max} = 1.1 * 15 * 21.77 = 359.20 \text{ m}$$

The armour layer design is also composed of different section. Result is shown in Table 13.

Table 13: Armour layer design at sea side of the tidal power plant.

Distance from orifice x (m)	Velocity u (m/s)	Theoretical value of Dn50 (mm)	Armour stone class	Practical value of Dn50 (mm)	Layer thickness t(mm)
0-65	5.18	579	HMA6000-10000	590	880
65-100	2.51	109	HMA300-1000	128	200
100-360	1.63	30	CP90/250	64	200

3.2.2 Sea side of pumping station

For the scour protection of pumping station at sea side, the design condition is without sea level rise and low tide at seaside. Water depth is given as $h=9.16$ m. Outflow of the pumping station is plane jet flow and half of orifice width is $B=2.5$ m.

The Chezy value for the at with initial base material is given as:

$$C = 18 * \log \left(12 \frac{R}{k_r} \right) 18 * \log \left(\frac{12 * 9.24}{0.1} \right) = 54.80$$

The critical flow velocity can be calculated as:

$$u_c = C \sqrt{\psi_c \Delta D_{n50}} = 54.80 * \sqrt{0.055 * 1.65 * 0.0002} = 0.233 \text{ m/s}$$

The final scour protection length is set to be 1400 m after iterative calculation. Calculation is given as follow. According former calculation, the jet flow velocity just at the orifice is $u_0=2.18$ m/s, and velocity of wave motion is $u_w= 1.56$ m/s. The velocity at the end of the bed protection is:

$$u = u_x + u_w = \frac{3.5u_0}{\sqrt{x/B}} + u_w = \frac{3.5 * 2.18}{\sqrt{1400/2.5}} + 1.56 = 1.582 \text{ m/s}$$

The equilibrium scour depth can be calculated :

$$h_{max} = \left(\frac{(0.5 * \alpha * u) - u_c}{u_c} \right) * h_0 = \left(\frac{0.5 * 3 * 1.582 - 0.233}{0.233} \right) * 9.24 = 84.81 \text{ m}$$

With safety factor $\gamma = 1.1$, $n_s=15$, the scour protection is given as:

$$L \geq \gamma n_s h_{max} = 1.1 * 15 * 84.81 = 1399.45 \text{ m}$$

The armour layer of the scour protection has two sections. Final design is listed in table 14.

Table14: Armour layer design at sea side of the pumping station.

Distance from orifice x (m)	Velocity u (m/s)	Theoretical value of D_{n50} (mm)	Armour stone class	Practical value of D_{n50} (mm)	Layer thickness t(mm)
0-50	5.18	308	LM _A 40-200	340	520
50-1400	2.51	55	CP90/250	64	200

3.2.3 The Getijmeer side of Spillway

For scour protection at the Getijmeer side for spillway, the design condition is without sea level rise and low tide in the Getijmeer. It's also plane jet flow for spillway with B=2.5 m. The water depth is h=8.79.

The critical flow velocity can be calculated :

$$C = 18 * \log \left(12 \frac{R}{k_r} \right) = 18 * \log \left(\frac{12 * 8.79}{0.1} \right) = 54.42$$

$$u_c = C \sqrt{\psi_c \Delta D_{n50}} = 54.42 * \sqrt{0.055 * 1.65 * 0.0002} = 0.232 \text{ m/s}$$

The final scour protection length is set to be 550 m after iterative calculation. Calculation is given as follow. The flow velocity just at the orifice is $u=u_0=3.16$ m/s. Velocity at the end of scour protection is .

$$u = u_x = \frac{3.5u_0}{\sqrt{x/B}} = \frac{3.5 * 3.16}{\sqrt{550/2.5}} = 0.745 \text{ m/s}$$

The equilibrium scour depth can be calculated :

$$h_{max} = \left(\frac{(0.5 * \alpha * u) - u_c}{u_c} \right) * h_0 = \left(\frac{0.5 * 3 * 0.745 - 0.232}{0.232} \right) * 8.76 = 33.61 \text{ m}$$

With safety factor $\gamma = 1.1$, $n_s=15$, the scour protection is given as:

$$L \geq \gamma n_s h_{max} = 1.1 * 15 * 33.61 = 550.47 \text{ m}$$

The armour layer of the scour protection has two sections. Final design is listed in table 15.

Table15: Armour layer design at the Getijmeer side of the spillway.

Distance from orifice x (m)	Velocity u (m/s)	Theoretical value of D_{n50} (mm)	Armour stone class	Practical value of D_{n50} (mm)	Layer thickness t(mm)
0-60	3.16	169	LM _A 5-40	170	250
60-550	2.26	56	CP90/250	64	200

3.3 Probabilistic check

Up to now, the required rock size for the armour layer stability is decided by deterministic approach. Considering uncertainty of the parameters used in the calculation, the result is check with probabilistic design approach. Here in this case FORM method is used. With limited time and effort, these process is only done for the armour layer just at the orifice of the spillway. So the armour stone size is given as $d_{n50}=0.17$ m.

The calculation of the probabilistic design is based on Prob2B, where several parameter and a limit state function is needed as input. While in the deterministic design, most of the parameters are set to be constant, which in reality is not the case. So to determine the values of the parameters that are used in the probabilistic design, the following starting points are taken into account.

- Density and gravitation acceleration (g, ρ_w, ρ_s) is considered to be normal distributed in a practical situation.
- The bottom at the outflow will be a little diverge from flat bottom. So slop correction coefficient K_s will be normal distributed with a 5% standar deviation.
- The fetch is reading from the layout of the DELTA 21 project with great uncertainty. So the stand deviation is set to be 0.1.
- Offshore wave height is Weibull distribution according to previous calculation, parameter has also been developed.
- For the water depth h at the target location, is effected by several factors including tide, wave set up and accurate measurement. The stand deviation is set to be 0.1.
- Average water depth in the Getijmeer is estimated roughly estimated according to the depth contour. The stand deviation is set to be 0.1.
- Maximum river discharge Q_{max} allowed through tidal power plant towards sea side is controlled by human operation. This leads to a large standard deviation of 0.1.
- Total length of the spill way L is given as 360 m. But considering variation during construction and width of septum between different outlets, this parameter holds a standard deviation of 0.1.
- For the value of d_{n50} , it's set to be normal distributed due to the uncertainty in the size of delivered material. The standard deviation is set to be 5% with qualified production.
- The turbulence density r at the mixing layer will be highly varied due to the unacurate assumption, so with a 0.1 standard deviation.

Table 16: Input Parameters in Prob2B

Parameter		Symbol	Distribution	Mean	Standard deviation
Gravity acceleration	g	g	Normal	9.81	0.01
Slop factor	K_s	Ks	Normal	1	0.05
Fetch	F	F	Normal	10000	1000
Offshore wave height	H_s	Hs	Weibull	k=1.04,u=3.009,e=2.503	
Water depth	h	h	Normal	9.16	0.916
Average water depth	$h_{average}$	h_average	Normal	2	0.2
Attack angle	φ	phi	Normal	0	10
Maximum river discharge	Q_{max}	Qmax	Normal	4000	400
Length of spillway	L	L	Normal	360	36
Shields parameter	ψ_c	psi_c	Deterministic	0.055	-
Water density	ρ_w	rho_w	Normal	1000	5
Rock density	ρ_s	rho_s	Normal	2650	100
	κ	k	Normal	$2.2 \cdot 10^{-6}$	-
Rock size	d_{n50}	dn50	Normal	0.21	0.0105
Turbulence in jet flow	r	r	Normal	0.3	0.03
Turbulence in uniform flow	r_{cu}	rcu	Deterministic	0.11	0.011

For the limited state function, it can be developed from Shields equation, where we can get

$$Z = d_{n50} - \frac{K_v^2 u^2}{K_s \psi_c \Delta C^2}$$

Other Expression used in Prob2B is given in table 17.

Table 17: In put expressions in Prob2B

Parameter	Symbol	Expression
Z	Z	$dn50 - (K_v^2 u^2) / (K_s \psi_c \Delta C^2)$
u	u	$Q_{max} / (L * (h - \Delta h_w))$
Δh_w	delta_hw	$0.5 * k * U_{10}^2 / (g * h_{average}) * F * \cos(\phi)$
U_{10}	U10	$\sqrt{g * H_s / 0.24}$
K_v	Kv	$(1 + 3 * r) / (1 + 3 * r_{cu})$
C	C	$18 * \log(12 * (h - \Delta h_w) / 6 * dn50)$
Δ	delta	$(\rho_s - \rho_w) / \rho_w$

Table 18: Probabilistic calculation result

Rock size d_{n50} (m)	Method	P_f	$P_{f,50}$
0.21	FORM	$7.215 \cdot 10^{-6}$	$7.21 \cdot 10^{-4}$

Based on the calculation in Prob2B using FORM, we can directly get the annual failure probability of scour protection. The overall failure probability within the design life time is calculated as

$$P_{f,100} = 1 - (1 - P_f)^{100}$$

The result is list table 18. The result from the calculation is quite acceptable to satisfy the required failure probability 1/28 and the final design seems conservative. But considering the uncertainty in several assumptions in the calculation, whether stones with smaller size should be used needs further development of the accuracy of the parameters.

3.4 Filter layer design

For a geometrically closed filter, filter between the armour layer and the sandy bed is to prevent the release of the base material through the gap of face layer. To reach this requirement, certain criteria is applied on the relation of gradient between different filter layers.

It's chosen to implement a geometrically closed granular filter. For the determination of the filter layers, the following three rules have been applied:

$$\text{Stability: } \frac{d_{15F}}{d_{85B}} < 5, \quad \text{Int.Stability: } \frac{d_{85}}{d_{15}} < 12, \quad \text{Permeability: } \frac{d_{15F}}{d_{15B}} > 5$$

Some rock smaller than CP45/125 used for the filter layers is not contained in European standard EN13383. While these grading can be found in EN13242. From the sandy base to the top armour layer, several filter layer is built up for different section of scour protection. For the layer of heavy grading and light grading, layer thickness is $t=1.5*d_{n50}$. For coarse grading, layer thickness is set to be $t=0.2$ m (Schierec, 2016). Sketches of the scour protection cross-section is at different part is in Appendix D.

3.4.1 Tidal power plant

Sea side

According to previous design for the armour layer, scour protecton of tidal power pant at sea side has four sections. Filter layer deisgn at different distance from the orifice is developed, and result is listed in table 19-22.

Table 19: Granular filter design at distance 0-55 m

Layer number	Type	d ₅₀ (mm)	d ₁₅ (mm)	d ₈₅ (mm)	Layer thickness t(mm)
Foundation	Medium sand	0.2	0.1	0.35	-
Filter layer 1	Coarse grading	-	1	10	200
Filter layer 2	Coarse grading	-	6	60	200
Filter layer 3	LM _A 10-60	210	±155	±283	320
Armour layer	HM _A 6000-10000	1440	±1313	±1556	2160

Table 20: Granular filter design at distance 55-120 m

Layer number	Type	d ₅₀ (mm)	d ₁₅ (mm)	d ₈₅ (mm)	Layer thickness t(mm)
Foundation	Medium sand	0.2	0.1	0.35	-
Filter layer 1	Coarse grading	-	1	10	200
Filter layer 2	Coarse grading	-	6	60	200
Filter layer 3	CP90/250	128	90	250	200
Armour layer	HMA300-1000	650-750	±483	±723	880

Table 21: Granular filter design at distance 120-200 m

Layer number	Type	d ₅₀ (mm)	d ₁₅ (mm)	d ₈₅ (mm)	Layer thickness t(mm)
Foundation	Medium sand	0.2	0.1	0.35	-
Filter layer 1	Coarse grading	-	1	10	200
Filter layer 2	Coarse grading	-	6	60	200
Armour layer	CP90/250	125-180	90	250	200

Table 22: Granular filter design at distance 200-1050 m

Layer number	Type	d ₅₀ (mm)	d ₁₅ (mm)	d ₈₅ (mm)	Layer thickness t(mm)
Foundation	Medium sand	0.2	0.1	0.35	-
Filter layer 1	Coarse grading	-	1	10	200
Filter layer 2	Coarse grading	-	6	60	200
Armour layer	CP45/125	63-90	45	125	200

The Getijmeer side

At Getijmeer side, sour protection of tidal power plant has three sections. Design of granular filter is presented in table 23-25.

Table 23: Granular filter design at distance 0-65 m

Layer number	Type	d ₅₀ (mm)	d ₁₅ (mm)	d ₈₅ (mm)	Layer thickness t(mm)
Foundation	Medium sand	0.2	0.1	0.35	-
Filter layer 1	Coarse grading	-	1	10	200
Filter layer 2	Coarse grading	-	6	60	200
Filter layer 3	CP90/250	128	90	250	200
Armour layer	HMA300-1000	650-750	±483	±723	880

Table 24: Granular filter design at distance 65-100 m

Layer number	Type	d ₅₀ (mm)	d ₁₅ (mm)	d ₈₅ (mm)	Layer thickness t(mm)
Foundation	Medium sand	0.2	0.1	0.35	-
Filter layer 1	Coarse grading	-	1	10	200
Filter layer 2	Coarse grading	-	6	60	200
Armour layer	CP90/250	125-180	90	250	200

Table 25: Granular filter design at distance 100-360 m

Layer number	Type	d ₅₀ (mm)	d ₁₅ (mm)	d ₈₅ (mm)	Layer thickness t(mm)
Foundation	Medium sand	0.2	0.1	0.35	-
Filter layer 1	Coarse grading	-	1	10	200
Filter layer 2	Coarse grading	-	6	60	200
Armour layer	CP45/125	63-90	45	125	200

3.4.2 Sea side of pumping station

Scour protection for the pumping station has two section, Table 26-27 gives the result of filter design.

Table 26: Granular filter design at distance 0-50 m

Layer number	Type	d ₅₀ (mm)	d ₁₅ (mm)	d ₈₅ (mm)	Layer thickness t(mm)
Foundation	Medium sand	0.2	0.1	0.35	-
Filter layer 1	Coarse grading	-	1	10	200
Filter layer 2	Coarse grading	-	6	60	200
Armour layer	LM _A 40-200	370-420	±247	±423	520

Table 27: Granular filter design at distance 50-1400 m

Layer number	Type	d ₅₀ (mm)	d ₁₅ (mm)	d ₈₅ (mm)	Layer thickness t(mm)
Foundation	Medium sand	0.2	0.1	0.35	-
Filter layer 1	Coarse grading	-	1	10	200
Filter layer 2	Coarse grading	-	6	60	200
Armour layer	CP45/125	63-90	45	125	200

3.4.3 The Getijmeer side of spillway

Filter design of scour protection near spillway is presented in Table 28-29.

Table 28: Granular filter design at distance 0-50 m

Layer number	Type	d ₅₀ (mm)	d ₁₅ (mm)	d ₈₅ (mm)	Layer thickness t(mm)
Foundation	Medium sand	0.2	0.1	0.35	-
Filter layer 1	Coarse grading	-	1	10	200
Filter layer 2	Coarse grading	-	6	60	200
Armour layer	LM _A 5-40	125-180	±90	±250	250

Table 29: Granular filter design at distance 50-550 m

Layer number	Type	d ₅₀ (mm)	d ₁₅ (mm)	d ₈₅ (mm)	Layer thickness t(mm)
Foundation	Medium sand	0.2	0.1	0.35	-
Filter layer 1	Coarse grading	-	1	10	200
Filter layer 2	Coarse grading	-	6	60	200
Armour layer	CP45/125	63-90	45	125	200

4 Execution plan

4.1 Required material

With the final design scheme decided, quantity of required material is calculated and essential equipment is decided. For the stone classes in EN13383, the minimal dumping quantity of unit length with layer of $1.5 d_{n50}$ (kg/m^2) is given (Schierec, 2016). For coarse grading gravel. Its bulk density is given as $1520\text{-}1680 \text{ kg}/\text{m}^3$. Quantity and logistics for required material is listed in table 30. Here is taken as a mid-value as $1600 \text{ kg}/\text{m}^3$. Quarry “Les Grès de Pernes” located in France is chosen as the source of material. There is good road connection from the quarry towards the construction site, so the material is transported by dump trucks. Articulated dump trucks as a kind of off-highway dump truck, are suitable for driving with heavy loads, stones up to a size of 300 kg is transported with this kind of vehicles (Van der Bos and Verhage, 2018). Other smaller grading is transported with highway dump trucks.

Table 30: Material quantity and logistics

Material	Quantity	Source	Transport
HM _A 6000-10000	179t	Quarry ”Les Grès de Pernes”	Articulated dump trucks
HM _A 300-1000	173t	Quarry ”Les Grès de Pernes”	Articulated dump trucks
LM _A 40-200	468t	Quarry ”Les Grès de Pernes”	Highway dump truck
LM _A 10-60	31t	Quarry ”Les Grès de Pernes”	Highway dump truck
LM _A 5-40	25t	Quarry ”Les Grès de Pernes”	Highway dump truck
Coarse grading(6-60mm)	1080t	Quarry ”Les Grès de Pernes”	High way dump truck
Coarse grading(1-10mm)	1080t	Quarry ”Les Grès de Pernes”	High way dump truck

4.2 Construction stages

The scour protection will be constructed with waterborne equipment. Description of the construction stages is given as follow.

- Bottom survey: Before the construction of the scour protection, the bottom profile and potential a pipe-line needs to be known to avoid unnecessary damage.
- Construction of the granular filter : Several filter layers with certain thickness is constructed with controlled placement without interrupting each other. This is done by fall-pipe vessel.
- Placing of the armour layer: Armour layer is composed of stone with larger size,

but still controlled placement is needed. This is done by side dumping vessel.

4.3 Risk analysis

Before the construction, it's crucial to take potential risks into account. Four risks that may occur is analysed in Table 31.

Table 31: Risk register

Risk	Description	Probability	Effect	MIitigation
1	Construction stage stability	Low	High	Try to make good weather forecast
2	Failure probability under estimated	Medium	High	Good study and prediction of the parameters that are used
3	Uncertainty in wave climate	High	Medium	Collect more wave data for a better wave prediction.
4	Workability of waterborne equipment	Medium	Low	Try to make good wave climate forecast at project planning stage

Risk 2 is related to the probabilistic check. For the scour protection at the sea side, onshore wave distribution will be needed in Prob2B. So it's very important to get accurate determination of nearshore wave distribution based on data of propagated wave from Swanone.

5 Conclusion and recommendation

5.1 Conclusion

The objective for this report is to scour protection for the DELTA 21 project with a 100 years design lifetime. Scour protection of tidal power plant is designed for a daily working condition, with every year repairment allowed, return period for the design condition is 1 year. Scour protection at the pumping station and spillway is design for a flooding condition and according to flood safety requirement and failure mechanism of the structure, return period of design condition is 2800 years.

Granular filter and stone armour layer is applied for the scour protection. The armour stone size is first decided and shows a progressively decreasing of stone size in the direction of away from the orifice. Filter layer is developed according to the rule of closed filter. Moreover, armour stability at orifice of spillway is checked with probabilistic approach, which shows the final design to be conservative.

Transportation of the material is by dump track from quarry “Les Grès de Pernes” in France. Construction is based on waterborne equipment.

5.2 Recommendation

Given the large value of alpha for the water depth in the FORM calculation (Figure 36), its parameter uncertainty very large compared to the others, so optimizing the uncertainty of this parameter seems important.

For the design water depth in this study, several factors is considered, including tide, sea level rise, wave set-up and wind set-down in the Getijmeer.

The sea level rise, according to the Veerman Committee, sea level rise by 2120 is up to 0.9-1.9 m, with the median equal to 1.4 m. While this seems to be an extreme high value which will lead to submerge of certain area in Netherlands. Climate change now has been brought to the forefront. The Paris Agreement's has a long-term goal to keep the increase in global average temperature to well below 2 °C above pre-industrial levels and to limit the increase to 1.5 °C. So considering human activities in preventing further deteriorated of global warming, a lower value of sea level rise needs to be used, which needs further study.

Also, storm over the North sea will cause considerable storm surge at dutch coast, which is not included in the wave set-up in result of Swanone. Higher storm water level will allow more wave energy propagated onshore, but meanwhile the wave motion near the bottom will be reduced. So the effect for the scour protection design is not very clear.

Further more in the armour layer design, Shields method is applied.

$$d_{n50} = \frac{K_v^2 u^2}{K_s \psi_c \Delta C^2}$$

It's notable that the velocity used in the equation should be the mean velocity over depth of flow at certain location. But for the flow velocity calculation at sea side, velocity due to wave motion is included, which is the velocity near the bottom. K_v is turbulence factor applied only as correction for the mean flow velocity. Therefore the equation needs to be further developed.

Rederence

A Sample Research Proposal with Comments (n.d.). Retrieved from <http://www.uh.edu/~lsong5/documents/A%20sample%20proposal%20with%20comment.pdf>

Berke L., Lavooij H.(2018). DELTA21 en Waterveiligheid, DELTA21: Kostenbesparend alternatief voor dijkverhogingen. Retrieved from <https://www.delta21.nl/>.

De kern van het plan: een valmeer (n.d.). Retrieved from <https://www.delta21.nl/>

Jonkman S.N., Jorissen R.E. (2018). Flood defences Lecture notes (3rd edition). Delft, The Netherlands: Delft University of Technology.

Leo C. van Rijn(2018). Channel slopes of mud, silt and sand. Retrieved from : www.leovanrijn-sediment.com

Molenaar W.F., Voorendt M.Z. (2018). Manual hydraulic structures (edition February 2018). Delft, The Netherlands: Delft University of Technology.

Netherlands Organization for Applied Natural Sciences Research TNO. (2019). DINOloket. Retrieved from: <https://www.dinoloket.nl/ondergrondgegevens>

Schiereck G.J., Verhagen. H.J. (2016). Introduction to bed, bank and shore protection (2nd edition). Delft, The Netherlands: VSSD

Slomp R.(2012). Flood Risk and Water Management in the Netherlands, A 2012 update. The Netherlands: Rijkswaterstaat.

Template Project Proposal and Plan (2013). Retrieved from :https://ocw.tudelft.nl/wp-content/uploads/AE4010_project_template_1_.pd

Van der Bos J.P., Verhagen H.J. (2018). Breakwater design Lecture note CIE5308(Edition 2018). Delft, The Netherlands: Delft University of Technology.

Van der Most H., Tánzos I., De Bruijn K.M., Wagenaar D..(2014) New, risk-based standards for flood protection in the Netherlands (September 2014). São Paulo, Brazil:ICFM6

Veerman Committee (2008). Working together with water, A living land builds for its future. Delft, The Netherlands: Delft University of Technology.

Appendix A Extreme value analysis of wave condition

To find wave condition with certain return period, extreme value analysis is needed based on example dataset of 23 years' daily observation. From overview of the example data, it can be seen that there are two storm peaks over the direction interval from 220° to 300° and 300° to 20° . So the extreme will be developed separately for data in this two ranges.

First consider storm wave data within 220° to 300° as shown in Figure 31. Since we only interest in storm wave attack, so conditions corresponding to the small peak is filtered out. The threshold level for a storm is event is selected to be 2.5m, which lead to the total number of storm equals 213. So the number of storms per year is $N_s=217/23=9.43$. Good rule of thumb is to aim for approximately $N_s=10$ storms per year, so the original threshold level of 2.5m was good and we will use these results in the remainder in this case.

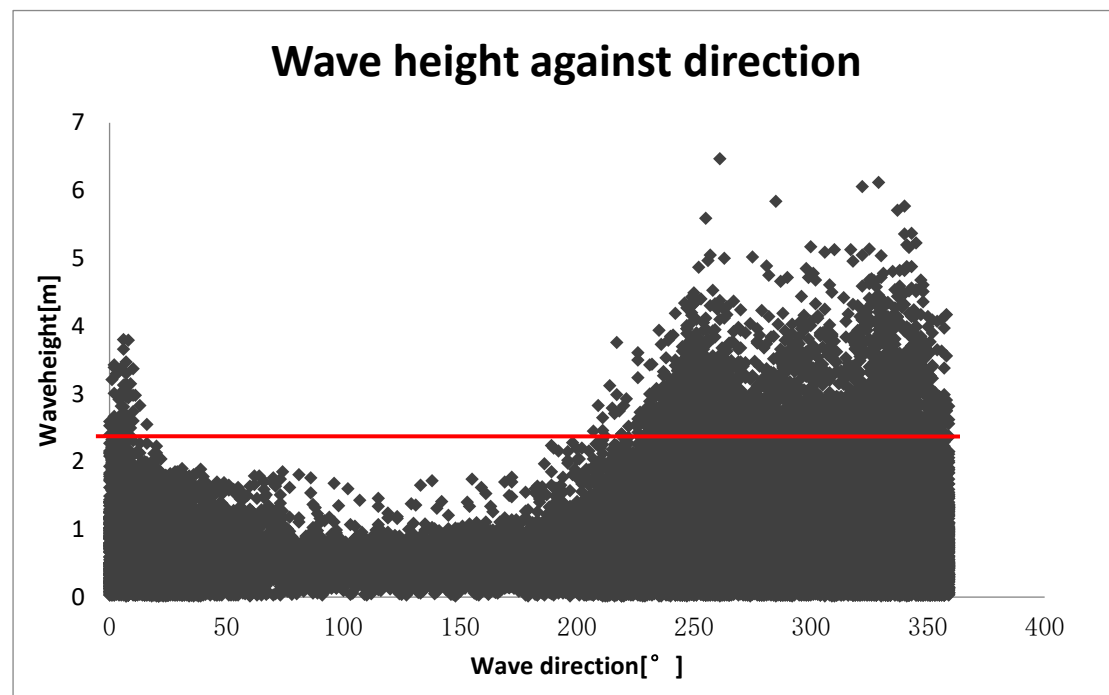

Figure 31: Quick scan of example dataset

Then the filtered data is proceed to fit the extreme value distributions (Exponential, Weibull, Gumbel and Generalized Pareto), which means that the distribution parameters α , β and γ is estimated. The first step is to rank the maximum wave height in per storm from the smallest to the highest and calculate exceedance probabilities P_i and Q_i according to $P_i=i/(N_i+1)$. Linear regression is used here to find the parameter for each distribution. Also for Weibull and GPD distribution, α is defined in a special way by trying different values to give the best fit with original data. The result of data fit in different distribution is given in figure 16. To chose between these types of distribution, it is also need to define a metric for the goodness-of-fit of the regression, such as Root Mean Square Error(RMSE):

$$RMSE = \sqrt{\frac{1}{N} \sum_{i=1}^N (H_{s,i} - H_{s,pred,i})^2}$$

Table 32: Estimated parameters extreme value distribution for linear regression method

	$\hat{\alpha}$	$\hat{\beta}$	$\hat{\gamma}$	RMSE
Exponential	-	0.479	2.522	0.014
Gumble	-	0.374	2.786	0.359
Weibull	1.040	0.506	2.503	0.004
GPD	-0.05	0.527	2.499	0.008

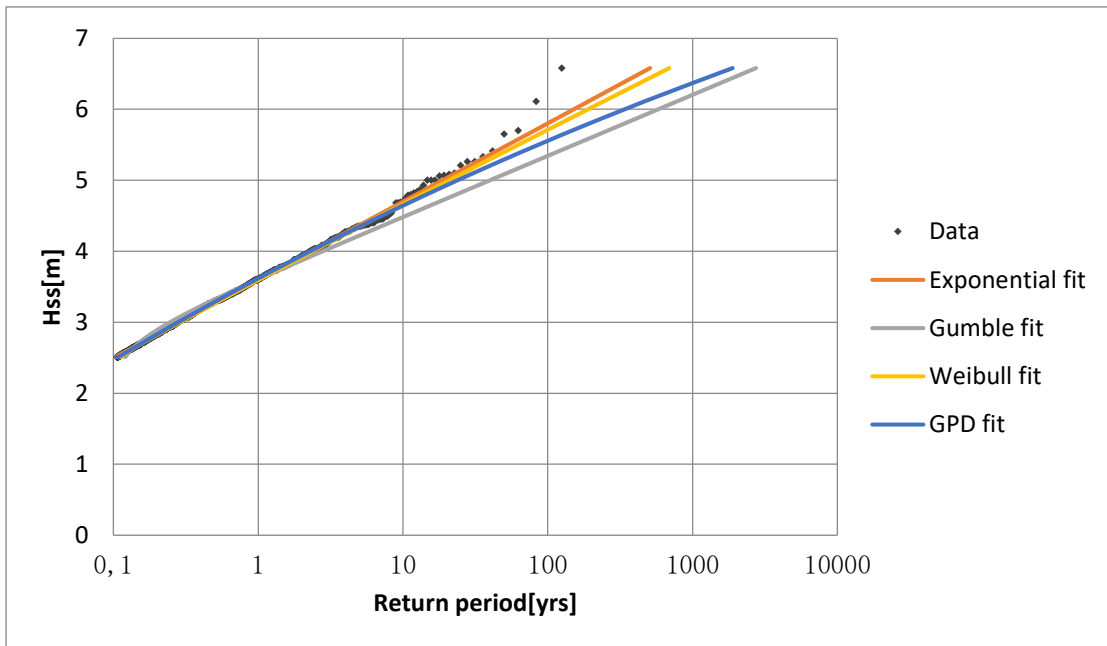

Figure 32: Result from extreme value analysis

Apparently, from both the RMSE values in table 6 and the visual representation of Figure 32, the Weibull and GPD distributions are the better choices among the four distributions. The Weibull results fit statistical better, the GPD results are more conservative which may lead to a relatively unstable design. So the Weibull distribution is chosen as the best fit.

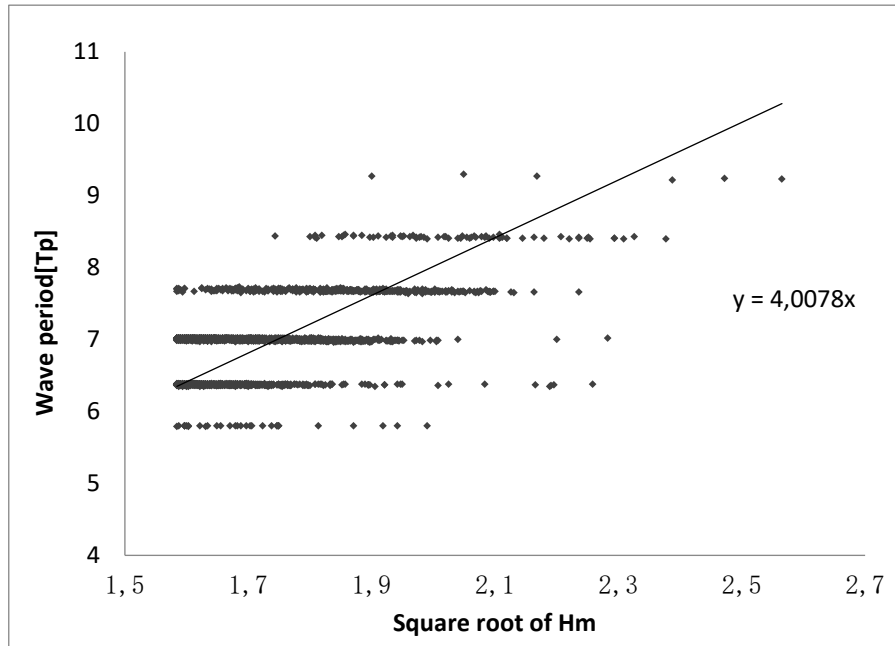

Figure 33: Correlation between wave height and wave period

To analyse the correlation between wave height and wave period and make a prediction for the corresponding wave period for each return period, a trend line is adding to the Figure 33. The peak period is proportional to square root of significant wave height. In this project, the correlation is given as $T_p = 4.01\sqrt{H_s}$.

Extreme value analysis for wave data among the region of 300° to 20° has the same steps. The calculation gives the result that Weibull is also the best fitted distribution over this range and the correlation between peak period and significant wave is given as $T_p = 4.85\sqrt{H_s}$.

Based on the design requirement, wave data with return period $R=1$ and 2800 years will be needed. Wave height and wave period predictions based on former chosen distribution is listed in Table 33. In the further calculation, wave comes from the two different direction ranges can be taken as wave from direction 260° and 340° , respectively.

Table 33: Design storm wave height and wave period predictions

Direction	340°		260°	
Return period(years)	1	2800	1	2800
Hs(m)	3.976	8.128	3.603	7.213

Appendix B Bottom profile

To get the onshore wave condition, wave transport simulation is done based on SwanOne. The bottom profile used in SwanOne is found through the website webapp.navionics.com.

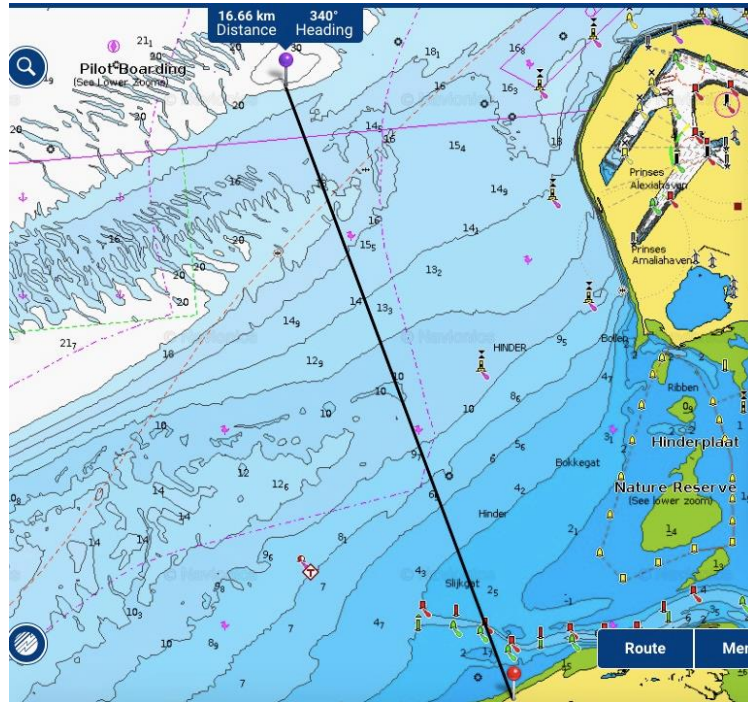

Figure 34: Depth contour from navionics

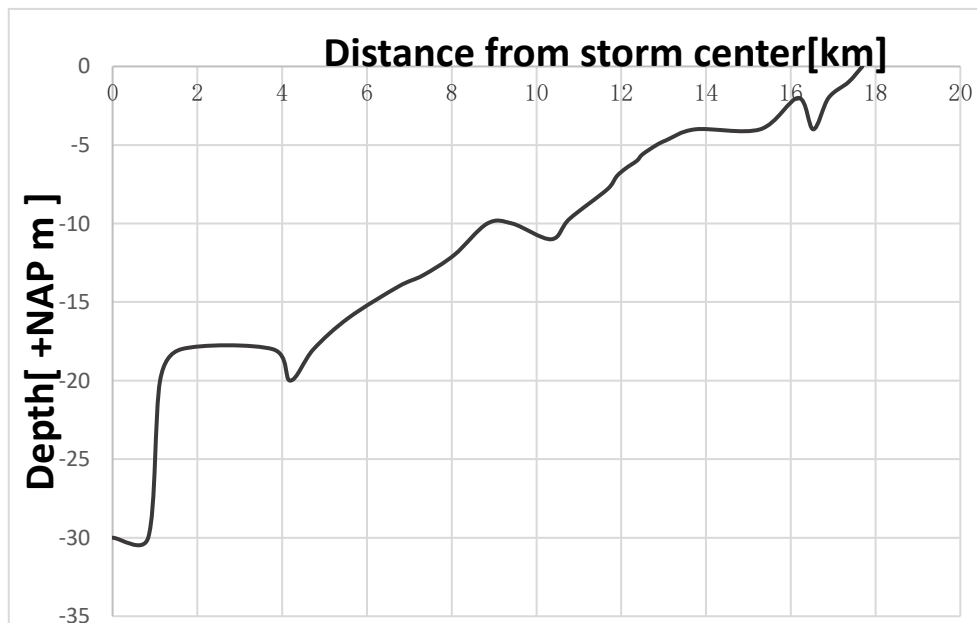

Figure 35: Bottom profile from storm center to coast

Appendix C Result of Prob2B

Number of calculations (FORM) : 273

Beta : 4.337E000

P_f : 7.215E-06

	Model	Parameter	alfa	X
1	Variable	F	-9.645E-03	1.004E004
2	Variable	Hs	-1.545E-02	2.886E000
3	Variable	Ks	1.072E-01	9.767E-01
4	Variable	L	5.188E-01	2.790E002
5	Variable	Qmax	-3.708E-01	4.643E003
6	Variable	dn50	5.833E-02	1.678E-01
7	Variable	h	7.151E-01	6.319E000
8	Variable	h_average	9.422E-03	1.155E000
9	Variable	k	0.000E00	2.200E-06
10	Variable	phi	1.445E-04	-6.268E-05
11	Variable	psi_c	0.000E00	5.500E-02
12	Variable	r	-1.950E-01	3.254E-01
13	Variable	rcu	1.056E-01	1.050E-01
14	Variable	rho_s	1.311E-01	2.593E003
15	Variable	rho_w	-1.732E-02	1.000E003

	z-value
1	1.445E-01
273	-1.098E-04

Figure 36: Calculation result of Prob2B

Appendix D Sketch of cross-section

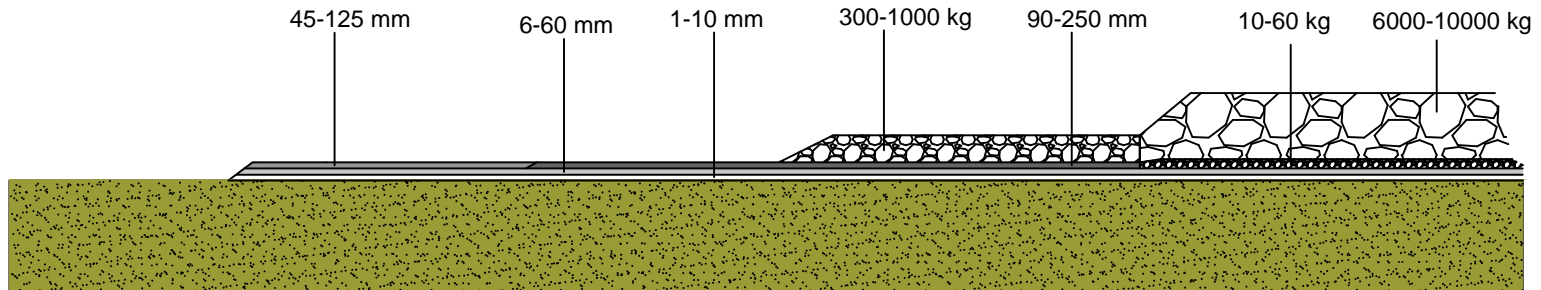

Figure 37: Cross-section of scour protection for tidal power plant at sea side

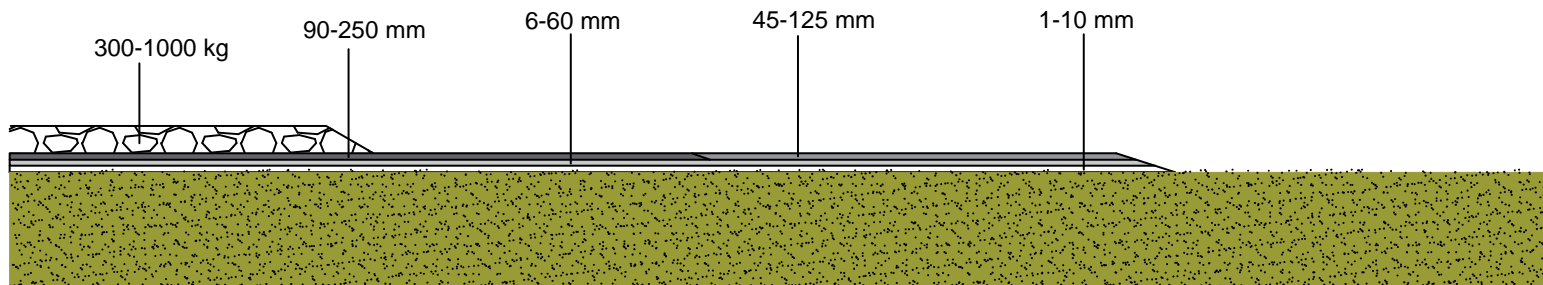

Figure 38: Cross-section of scour protection for tidal power plant at the Getijmeer side

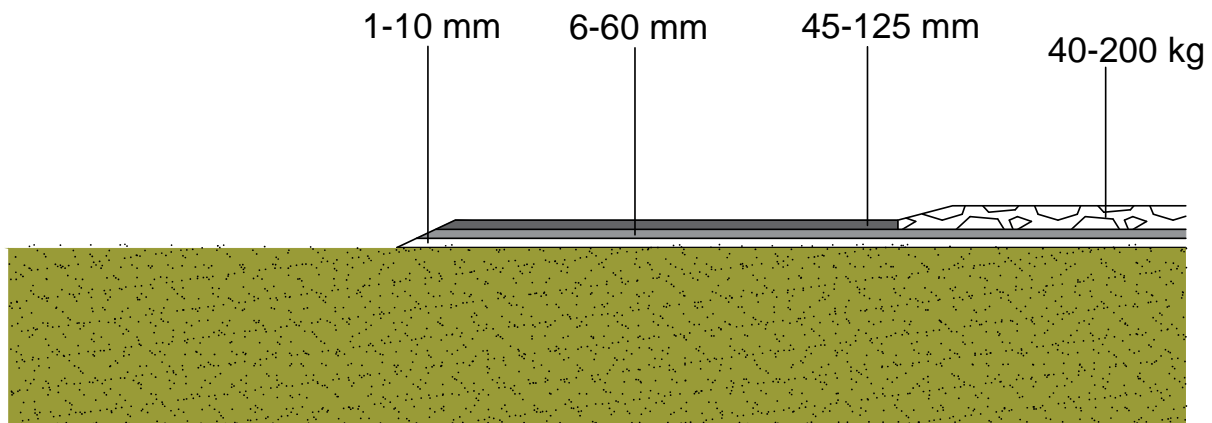

Figure 39: Cross-section of scour protection for pumping station at sea side

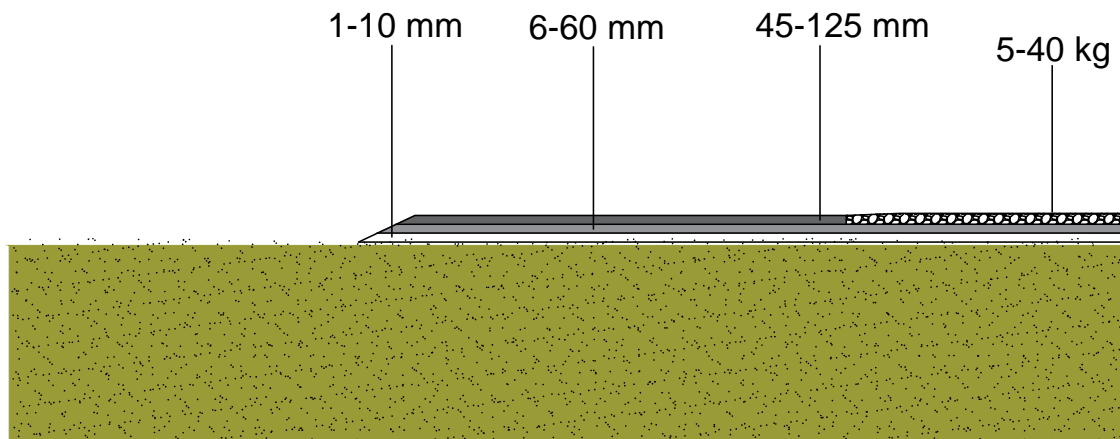

Figure 40: Cross-section of scour protection for spillway at the Getijmeer side